

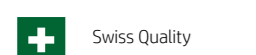

## PRODUKTION IM HERZEN EUROPAS PRODUCTION IN THE HEART OF EUROPE



Swiss Quality



Energieautarke Produktion  
Energy self-sufficient production



Flexible Lieferketten  
Flexible supply chains



Zero Waste - 100% Recycling der Produktionsreste  
Zero Waste - 100% recycling of production waste



Vermeidung von Übersee-Transporten  
Overseas transport avoided



Innovatives Know-How  
Innovative Know-How



## NACHHALTIGE KREISLAUFWIRTSCHAFT SUSTAINABLE CIRCULAR ECONOMY

Mit dem innovativen 2<sup>nd</sup> life – Verfahren eröffnen sich neue Möglichkeiten im Bereich Nachhaltigkeit und ressourcen-schonendes Recycling:

Hat der alte Boden ausgedient, oder besteht der Wunsch nach einem neuen Design, wird der ausgeklickte Boden vom ① Endkunde über den ② Fachhändler an ③ LICO zurückgeschickt. Hier wird das alte Design von den Bodenplatten abgeschliffen, diese werden anschliessend neu bedruckt, beschichtet und profiliert. Letztlich wird der neue Boden wieder in den Markt gebracht und als vollwertiger Boden vertrieben.

*The innovative 2<sup>nd</sup> life process opens up new possibilities in the field of sustainability and resource-saving recycling:*

*If the old floor has worn out, or if there is the wish for a new design, the clicked-out floor is sent back from the end customer ① via the retailer ② to LICO ③. Here, the old design is sanded off the floor panels, which are then newly printed, coated and profiled. Finally, the new floor is reintroduced to the market and distributed as a top quality floor.*

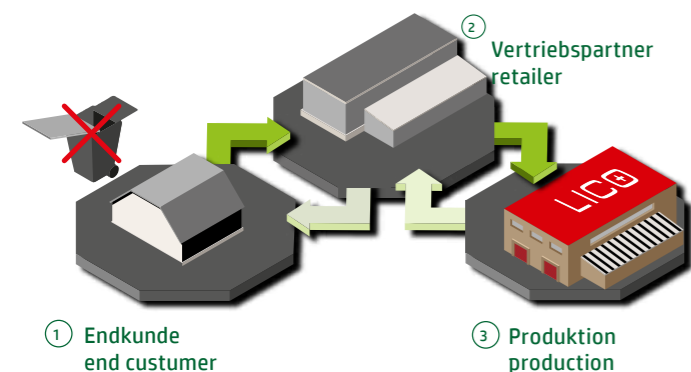

## Naturböden / Natural floors

Kork	5
Printcork	11
Lino	17
Lino Design	23
<b>NEW</b> Fibrano	27
Ledo	33
Realstone	37
Real Designwood	41
Micodur	45

## Designböden / Design floors

*Designböden Klasse 32 / Nutzschicht 0,30 mm / Design floors class 32 / wear layer 0,30 mm*

Vinyl Economy Plus	52
Vinyl Design 16	56
Vinyl Design Plus	58
Vinyl Suisse Edition	60
Vinyl Design 21	62

*Designböden Klasse 33 / Nutzschicht 0,55 mm / Design floors class 33 / wear layer 0,55 mm*

Vinyl Objekt	64
<b>NEW</b> Vinyl Objekt Syncro	68
Vinyl Stone Plus	71
Vinyl Longus	74

Hydro Fix	79
Hydro Fix Objekt	84
Vintex Fix	91

*Designböden PVC frei / Design floors PVC free*

Eco Design	95
Lipur	99

## Accessoires

Stairs	106
Skirtings	108

## Wandelemente / Wall coverings

Wall Hydro	113
Wall Hydro Print	117



## WILLKOMMEN

Das Verständnis für die Natur, das Arbeiten in einer intakten, natürlichen Umgebung, das Bearbeiten eines natürlichen und nachwachsenden Rohstoffes wie Kork, Lino oder Holz, das Schaffen eines echten, natürlichen Ambiente mit verschiedenen Boden-Produktlinien gepaart mit innovativen und kundenorientierten Grundsätzen ... das ist LICO ... das ist das wahre Konzept für eine erfolgreiche Partnerschaft. Seit den Anfangsjahren 1989 ist es der Firma LICO gelungen, sich zu einem modernen, erfolgreichen, innovativen und weltweit tätigen Produktionsunternehmen zu entwickeln. LICO zählt mittlerweile zu den führenden Unternehmen in dieser Branche, vor allem in Bezug auf Qualität, Flexibilität, Innovation und Zuverlässigkeit. Durch ständige Weiterentwicklung der Produktionsanlagen ist es für LICO eine Selbstverständlichkeit im Preis-Leistungs-verhältnis die globalen Anforderungen zu erfüllen.

## WELCOME

As an understanding for nature, working in an intact, natural environment, working with a natural and regenerative resource such as cork, lino or wood, creating a genuine natural ambience with different diversified flooring product lines, coupled with an innovative and customer-oriented philosophy... that is LICO ... that's the unadulterated concept for a successful partnership. Since 1989, LICO has been developing from a modest production company, into a highly modern, successful, innovative and global market player. LICO is now one of the leading companies within the flooring system industry, about high quality, great flexibility, continuous innovation and trustful reliability. Through continuous further development of the production systems, LICO is able to fulfill the global requirements of the flooring industry.



KORK - Murano

## KORK

### Ein Wunder der Natur

Unter Kork versteht man die Rinde der Korkeiche, die grösstenteils im Mittelmeerraum beheimatet ist. Kein Baum wird durch die Schälung der Korkrinde beschädigt oder gefällt. Die erste Schälung kann nach ca. 25 Jahren erfolgen, dann erntet man die nachwachsende "Isolierrinde" alle 8-9 Jahre. Korkeichen werden bis zu 200 Jahre alt, so kann eine Korkeiche bis zu 20 mal geschält werden.

Durch die Zellstruktur (ca. 40 Mio. Zellen pro  $\text{cm}^3$ ) besitzt dieser 100% ökologische Rohstoff einzigartige Eigenschaften. Jede dieser Zellen ist mit einem luftähnlichen Gas gefüllt. In ausgereiften Arbeitsprozessen wird dieses "Naturwunder" von LICO nach Schweizer Qualitätsstandard zu einem hochwertigen Fussboden veredelt.

### One of nature's wonders

Cork comes from the bark of the cork oak, a predominantly mediterranean tree, and is removed without having to fell the tree or damage it in any way. The first peeling takes place when the tree is about 25 years old and regrown "insulation bark" can then be harvested every 8-9 years afterwards. Cork oaks may well live anything up to 200 years which means that they provide something like twenty peelings.

Cork is a one hundred percent ecological raw material and owes its unique properties to its cell structure of approx. 40,000 cells per square cm. The individual cells contain an air-like gas. Cork is truly one of nature's wonders and LICO has developed their own special manufacturing processes to ensure that their products meet the exacting quality standards required by Swiss quality standards.v

Quadro



Linea



Flamenco Neu / Flamenco New



Mikado



Tigre



Murano



Murano



Nostalgie



Linea Dark



Mono



P-40



P-999



Madeira



Mosaik



Pazzo



Comprido



Elba



Rombo



Rombo Neu / Rombo New

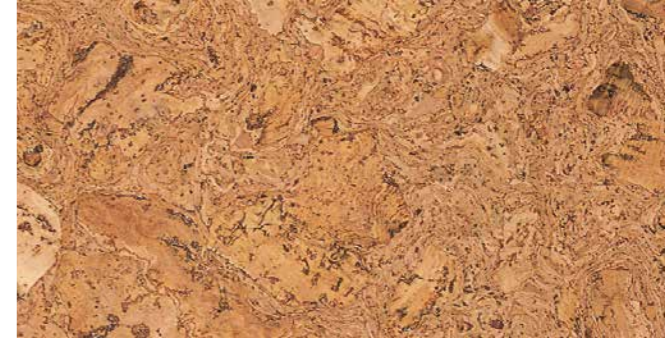



Fantasy Natur

**i** Einfärbe- Möglichkeiten für LICO Kork  
Designs können in den vorliegenden Farben eingefärbt werden.  
Coloring options for LICO Cork  
Designs can be colored in the available colors.



Fantasy White



Fantasy Creme



Fantasy Champagne



Fantasy Sand

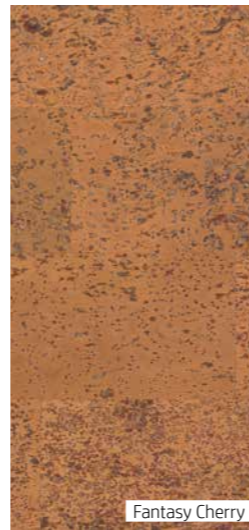

Fantasy Cherry



Fantasy Grey

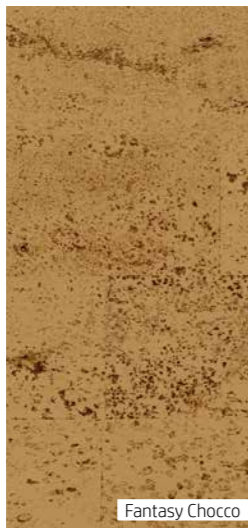

Fantasy Chocco



Fantasy Coffee



Fantasy Mocca



Fantasy Anthracite

HC Light Klasse / Class 23 / 32  
HC Klasse / Class 23 / 33

Naturprodukt  
Natural product

2nd life

Trittschall 18 dB  
Sound impact 18 dB

Pflegeleicht  
Easy to care

HDF ca. 11,0 mm

- HotCoating oder HotCoating Light  
HotCoating or HotCoating Light
- Korkfurnier  
Cork veneer
- Kork > 500 kg/m<sup>3</sup>  
Cork > 500 kg/m<sup>3</sup>
- Feuchtigkeitshemmende Natur Faserplatte  
Moisture retardant fibre-board
- Presskork Gegenzug  
Cork underlay

Fliese / Tile ca. 6,0 mm

- HotCoating oder HotCoating Light  
HotCoating or HotCoating Light
- Korkfurnier  
Cork veneer
- Korkträgerschicht  
Cork backing layer

Fliese / Tile ca. 4,0 mm

- HotCoating oder HotCoating Light  
HotCoating or HotCoating Light
- Korkfurnier  
Cork veneer
- Korkträgerschicht  
Cork backing layer



Rombo

- Fusswarm**  
Warm to the touch
- Strapazierfähig**  
Durable
- Schall- und Trittschallisolierung**  
Sound impact and phonic insulation
- Verwendung nachwachsender Rohstoffe**  
Use of regrowing raw material
- Wärmeisolierend**  
Thermal insulation
- Gelenkschonend**  
Soft to the tread
- Geeignet für Fussbodenheizung**  
Underfloor heating possible

Formate / Dimensions

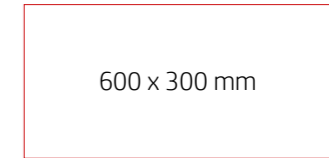
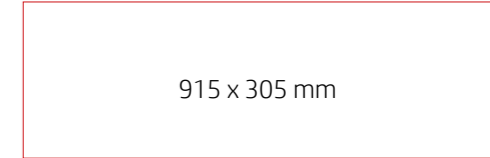



201547 Classy Oak Honey

## PRINTCORK

### Unendliche Designvielfalt

Printcork ist die Produktlinie von Kork-Naturböden, optimiert durch die Verwendung von Kork Composite als Oberbelag. Durch den Einsatz des Digitaldruckes erschliesst sich eine unbegrenzte optische Gestaltungsmöglichkeit.

Mittels dieser speziell entwickelten Drucktechnologie und dem Einsatz der neuesten Beschichtungstechnologien ist es LICO gelungen originelle und strapazierfähige Fussböden zu kreieren. Ausserdem wird das Ausbleichen bei direkter Sonneneinstrahlung verhindert.

Vom Kinderzimmer bis zum Objektbereich - für Printcork sind keine Grenzen gesetzt.

### An endless variety of designs

Printcork is the product line of natural cork floors, optimized with the Cork Composite technology, it is wellknown and proven outstanding technical properties, supplemented by the advantage of unlimited options for optical design. Furthermore it does not fade in direct sunlight.

From children rooms to object areas, there is no limitation in design and durability for Printcork.

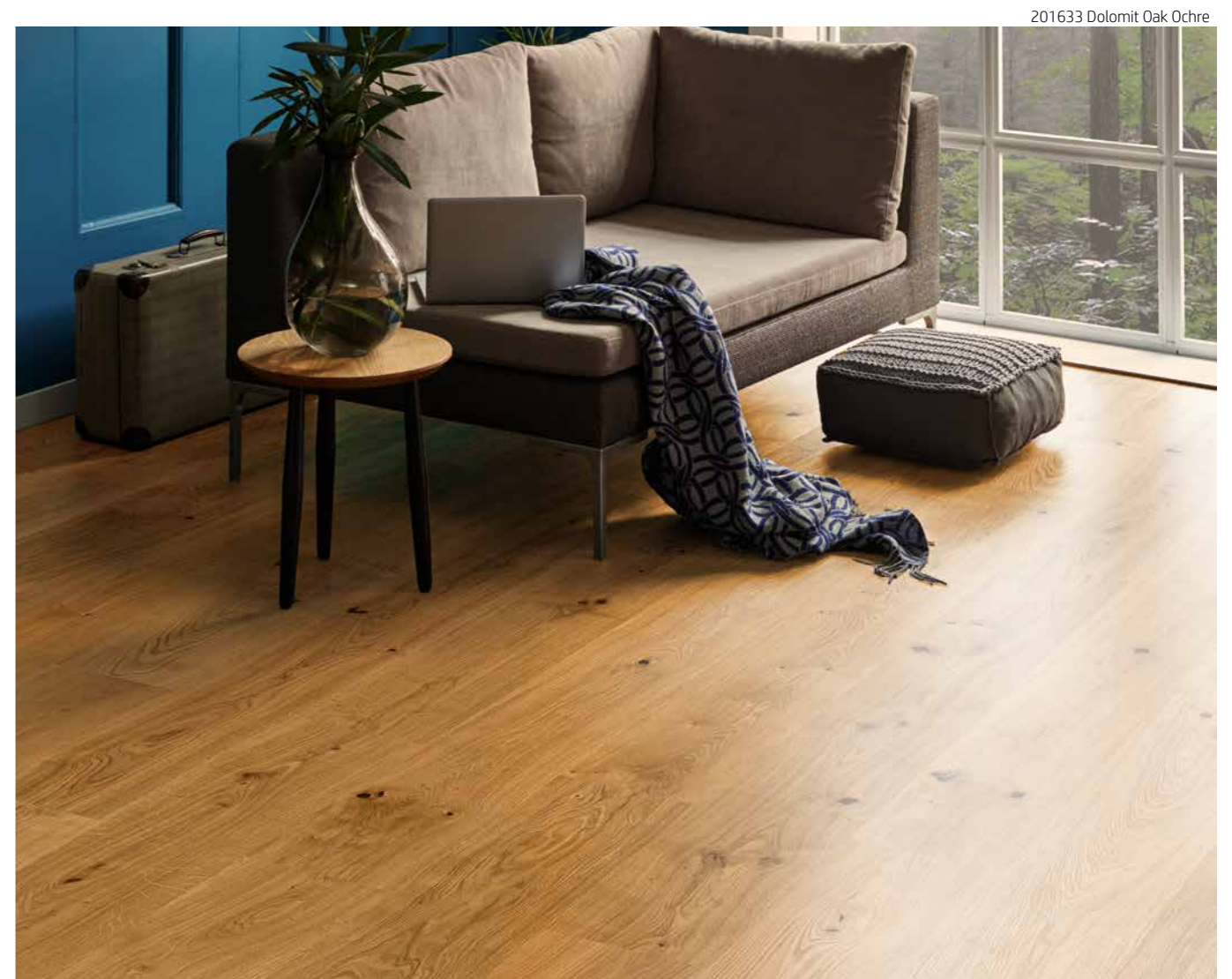
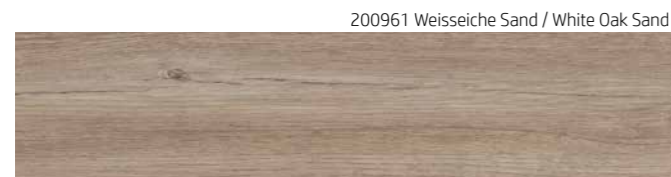

- Kork
- Printcork**
- Lino
- Fibrano
- Ledo
- Realstone
- Real DesignWood
- Micodur
- Vinyl
- Hydro Fix
- Vintex Fix
- Eco Design
- Lipur
- Zubehör
- Lico Wall



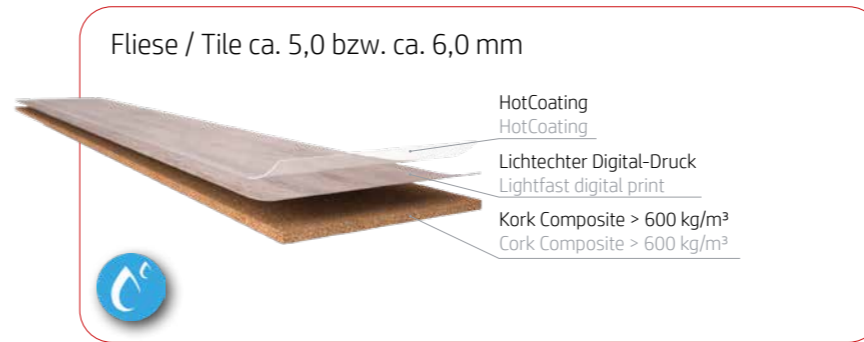
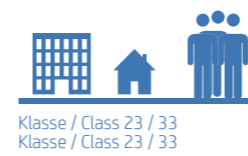
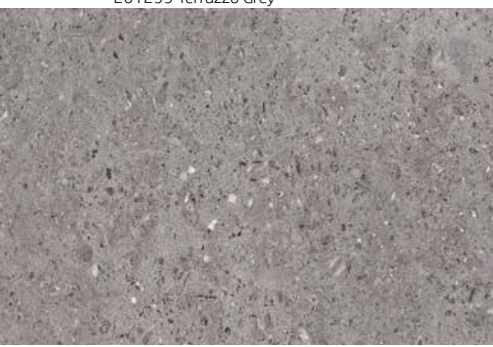
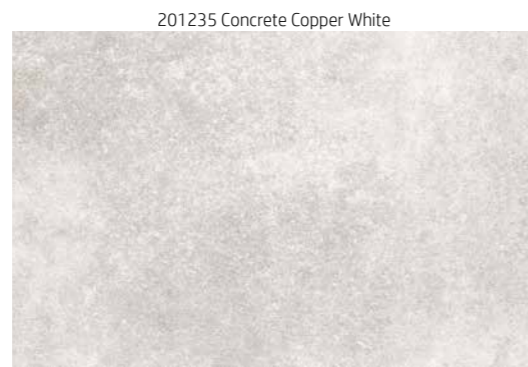

- Fusswarm**  
Warm to the touch
- Unendliche Designvielfalt**  
Designs at infinitum
- Schall- und Trittschallsolierung**  
Sound impact and phonic insulation
- Verwendung nachwachsender Rohstoffe**  
Use of regrowing raw material
- Wärmeisolierend**  
Thermal insulation
- Gelenkschonend**  
Soft to the tread
- Lichtechtheit >7**  
Light fastness >7

Formate / Dimensions

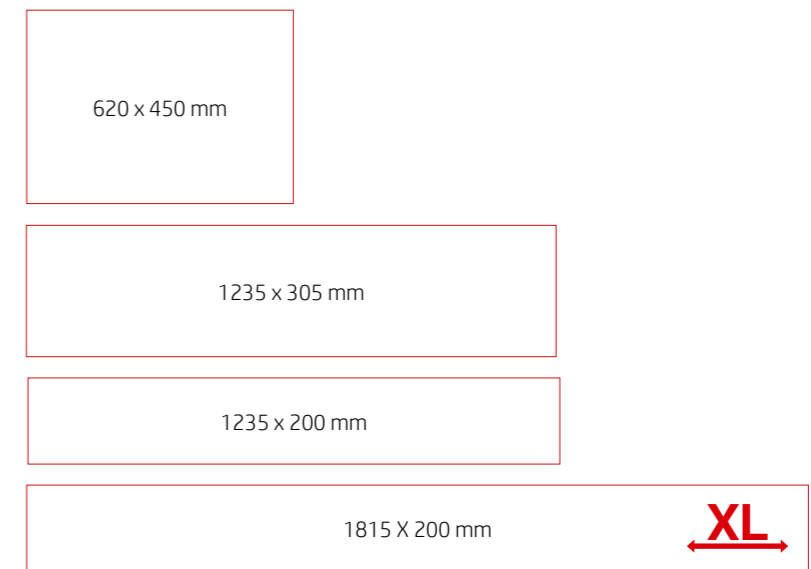

Kork  
Printcork  
Lino  
Fibrano  
Ledo  
Realstone  
RealDesignWood  
Microdur  
Vinyl  
Hydro Fix  
Vintex Fix  
Eco Design  
Lipur  
Zubehör  
Lico Wall



## LINO

### Linoleum... eine erstaunliche Symbiose der Natur

Linoleum, ein seit über hunderte von Jahren bewährter Naturboden, ist durch neue Produktionstechniken ein höchst interessanter Bodenbelag für die verschiedensten Anwendungsbereiche geworden. Vom Kinderzimmer über das Büro und von der Arztpraxis bis hin zur Designer Boutique.

Was ist eigentlich Linoleum?

Linoleum wird hergestellt aus Leinöl, Kiefernharz, Kalkstein, Kork-Holzmehl, Erdfarben - als Trägermaterial dient Jute. Seit Jahrzehnten wird nun dieses strapazierfähige Naturprodukt von LICO nach Schweizer Qualitätsbewusstsein zu einem hochwertigen Präzisions-Fertigboden verarbeitet.

### Linoleum... a delightful symbiosis from nature

Linoleum, a completely natural flooring material, has been tried and tested for over one hundred years. New production techniques help to make it a top choice for a wide variety of use in children's bed-rooms, offices and doctor's surgeries to designer boutiques.

What is exactly linoleum?

Linoleum is made from linseed oil, pine resin, limestone, cork and sawdust with jute fibre acting as the carrier material and is available in a range of nature earth-tone colours. LICO has been producing, hard-wearing natural linoleum precision flooring for decades and their very popular product conforms to the very highest Swiss quality standards.

685





3866

Klasse 23 / 32  
Class 23 / 32

Naturprodukt  
Natural product

2nd life

Fussbodenheizung  
Underfloor heating

Pflegeleicht  
Easy to care

**HDF ca. 10,0 mm**

- Hochstrapazierfähige PU Beschichtung  
Hardwearing PU Protection
- Linoleumboden  
Linoleum flooring
- Feuchtigkeitshemmende Natur Faserplatte  
Moisture retardant fibre-board
- Presskork Gegenzug  
Cork Underlay

**Klebefiese / Adhesive tile ca. 4,0 mm**

- Hochstrapazierfähige PU Beschichtung  
Hardwearing PU Protection
- Linoleumboden  
Linoleum flooring
- Kork Composite  
Cork composite

**Rollenware / Rolls ca. 2,5 mm *auf Anfrage/on request***

- Hochstrapazierfähige PU Beschichtung  
Hardwearing PU Protection
- Linoleumboden  
Linoleum flooring

- Fusswarm**  
Warm to the touch
- Strapazierfähig**  
Durable
- Schall- und Trittschallisolierung**  
Sound impact and phonic insulation
- Verwendung nachwachsender Rohstoffe**  
Use of regrowing raw material
- Wärmeisolierend**  
Thermal insulation
- Gelenkschonend**  
Soft to the tread

Formate / Dimensions

915 x 305 mm

620 x 450 mm

- Kork
- Printcork
- Lino**
- Fibrano
- Ledo
- Realstone
- RealDesignWood
- RealDesignWood
- Micodur
- Vinyl
- Hydro Fix
- Vintex Fix
- Eco Design
- Lipur
- Zubehör
- Lico Wall



201627 Kayaeiche Meadow / Kaya Oak Meadow

## LINO DESIGN

### Grenzenlose Designvielfalt

Linoleum ist ein bewährter Naturboden, bestehend aus Leinöl, Kiefernharz, Kalkstein, Kork-Holzmehl und Erdfarben, bisher eingeschränkt durch seine Designmöglichkeiten. Durch eine neuartige Formulierung ist es erstmals gelungen ein absolut massstabiles und wasserfestes Linoleum zu entwickeln.

Lino Design kombiniert nun dieses Naturprodukt mit den Möglichkeiten des Digitaldruck. Dadurch entsteht der ideale Bodenbelag für individuelle Objekt- und Wohnbereiche. Der Vielfalt an Designs sind keine Grenzen gesetzt. Lino Design überzeugt durch seine sehr hohe Strapazierfähigkeit, ohne dabei die positiven natürlichen Eigenschaften zu beeinträchtigen.

### Boundless design variety

Linoleum is a proven natural floor, consisting of linseed oil, pine resin, limestone, cork sawdust and natural earth-tone colors, until now limited by its design possibilities. Through an innovative formulation, it is the first time succeeded to develop an absolutely dimensionally stable and waterproof linoleum.

Lino Design combines this natural product with the possibilities of digital printing, creating the ideal flooring for individual object- and domestic areas. The variety of designs are limitless. Convincing by its very high durability without any compromise to the positive natural properties.

201623 Savannah Oak Darkgrey



NEW

201591 Lärche Klotten / Larch Klotten



Eiche Levante Dunkel / Oak Levante Dark



NEW

201654 Eiche Monaco Bernstein / Oak Monaco Amber



NEW

201628 Clawson Oak Sand



201629 Mirabelleiche Caramell / Mirabell Oak Caramell



NEW

201626 Kayaeiche Wellington / Kaya Oak Wellington



NEW

201631 Mirabelleiche Raw Amber / Mirabell Oak Raw Amber



NEW

201627 Kayaeiche Meadow / Kaya Oak Meadow



NEW

201630 Mirabelleiche Rohholz / Mirabell Oak Raw Wood



NEW

201023 Ökobeton / Eco Concrete



201118 Stone Pearl



201022 Sichtbeton Hell



201018 Beton Terra / Concrete Terra



201303 Brown Floral Stone



201653 Ardesia Grey



Klasse / Class 23 / 33  
Klasse / Class 23 / 33

Naturprodukt  
Natural product

2nd life

Prägung  
Embossing

Pflegeleicht  
Easy to care

**HDF ca. 10,0 mm**

- HotCoating  
HotCoating
- Lichtechter Digital-Druck  
Lightfast digital print
- Linoleum  
Linoleum
- Feuchtigkeitshemmende Natur Faserplatte  
Moisture retardant fibre-board
- Presskork Gegenzug  
Cork underlay

**Fliese / Tile ca. 4,0 mm**

- HotCoating  
HotCoating
- Lichtechter Digital-Druck  
Lightfast digital print
- Linoleum Composite  
Linoleum Composite
- Kork Composite  
Cork Composite

- Fusswarm**  
Warm to the touch
- Unendliche Designvielfalt**  
Designs at infinitum
- Schall- und Trittschallisierung**  
Sound impact and phonic insulation
- Verwendung nachwachsender Rohstoffe**  
Use of regrowing raw material
- Wärmeisolierend**  
Thermal insulation
- Gelenkschonend**  
Soft to the tread
- Lichtechtheit >7**  
Light fastness >7

Eiche Monaco Bernstein / Oak Monaco Amber



Formate / Dimensions

620 x 390 mm

1235 x 200 mm

- Kork
- Printcork
- Lino**
- Fibrano
- Ledo
- Realstone
- RealDesignWood
- RealDesignWood
- Micodur
- Vinyl
- Hydro Fix
- Vintex Fix
- Eco Design
- Lipur
- Zubehör
- Lico Wall



FIBRANO -201535 Eiche Siena Dark / Oak Siena Dark

## FIBRANO

### Die plastikfreie, natürliche Alternative

Wir als LICO finden, es ist an der Zeit Nachhaltigkeit vom Anfang bis zum Ende zu denken und in all seinen Facetten umzusetzen. Mit LICO Fibrano® haben wir einen kunststoff-freien Naturboden entwickelt, der sich ausschliesslich aus nachwachsenden Materialien wie Holz, Kork, Naturfasern, Kautschuk und anderen natürlichen Rohstoffen zusammensetzt.

Gleichzeitig schaffen wir einen modernen, hochwertigen und komfortablen Bodenbelag der alle technischen Anforderungen des 21. Jahrhunderts erfüllt, selbst in Punkto Robustheit (Klasse 33).

Bei der Produktentwicklung wurde insbesondere auf eine nachhaltige Kreislaufwirtschaft (2<sup>nd</sup> life) Wert gelegt.

### The plastic-free, natural alternative

We at LICO believe it is time to think sustainability from the beginning to the end and to realize it in all its many facets. With LICO Fibrano® we have developed a plastic-free natural floor that is composed exclusively of renewable materials such as wood, cork, natural fibers, natural gums and other natural materials.

At the same time, we create a modern, high-quality and comfortable floor covering that meets all the technical requirements of the 21<sup>st</sup> century, even in terms of durability (class 33).

In the product development, particular focus was given to a sustainable circular economy (2<sup>nd</sup> life).

201555 Eiche Levante Grau / Oak Levante Grey



201551 Northern Oak Silver



201596 Northern Oak White



201534 Eiche Siena Taupe / Oak Siena Taupe



201534 Eiche Siena Taupe / Oak Siena Taupe



201535 Eiche Siena Dark / Oak Siena Dark



201536 Eiche Siena Gold / Oak Siena Gold



201532 Eiche Siena Natural / Oak Siena Natural



201554 Eiche Bourbon / Oak Bourbon



201552 Kirsche Französisch / French Cherry



201530 Cognaceiche / Cognac Oak



201537 American Red Oak



201542 Eiche Villa Natur / Oak Villa Natural



201541 Eiche Villa Gold / Oak Villa Gold



201543 Eiche Villa Light / Oak Villa Light



201546 French Oak Light



201539 Eiche Nairobi Sand / Oak Nairobi Sand



201538 Eiche Nairobi Beige / Oak Nairobi Beige



201541 Eiche Villa Gold / Oak Villa Gold



Kork

Printcork

Lino

Fibrano

Ledo

Realstone

Real DesignWood

Micodur

Vinyl

Hydro Fix

Vintex Fix

Eco Design

Lipur

Zubehör

Lico Wall





201327 Cement Light Ceramic



201556 Concrete Polished White



201327 Cement Light Ceramic



201595 Stone Birs Light



201399 Betonstein / Concrete Stone



201621 Concrete Urban



201166 Sandstein / Sandstone



201594 Beton Loft Dark



201518 Cement Ash



201598 Monte Carrara

Klasse / Class 23 / 33  
Klasse / Class 23 / 33

Naturprodukt  
Natural product

2nd life

Prägung  
Embossing

Pflegeleicht  
Easy to care

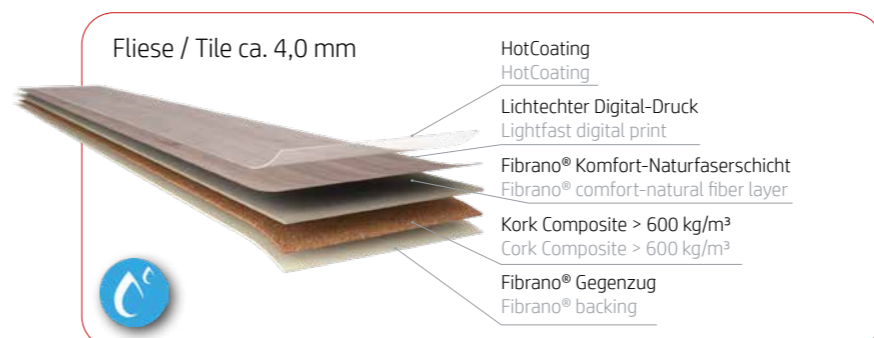
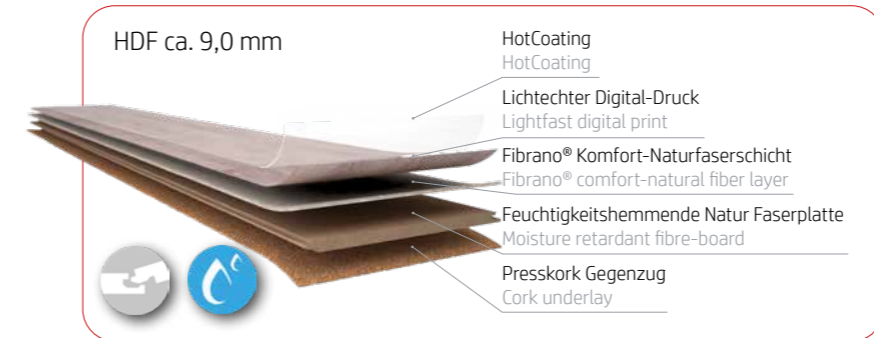

- Fusswarm**  
Warm to the touch
- Unendliche Designvielfalt**  
Designs at infinitum
- Schall- und Trittschallisierung**  
Sound impact and phonic insulation
- Verwendung nachwachsender Rohstoffe**  
Use of regrowing raw material
- Wärmeisolierend**  
Thermal insulation
- Gelenkschonend**  
Soft to the tread
- Lichtechtheit >7**  
Light fastness >7

Formate / Dimensions

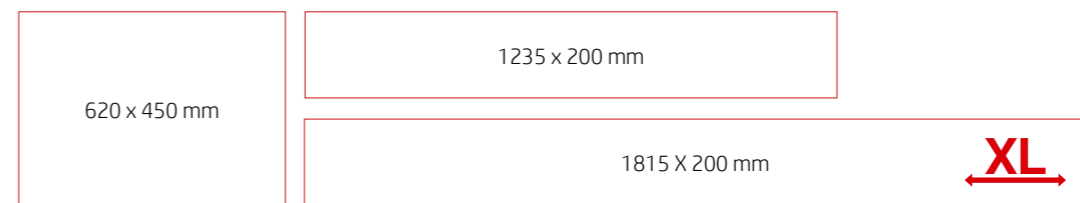

Kork  
Printcork  
Lino  
**Fibrano**  
Ledo  
Realstone  
RealDesignWood  
Microdur  
Vinyl  
Hydro Fix  
Vintex Fix  
Eco Design  
Lipur  
Zubehör  
Lico Wall



## LEDO

### Edel, innovativ und formschön

Der Leder-Fertigboden von LICO ist ein Leder-Faserstoff, welcher aus echtem, recyceltem, chromfreiem Leder, Naturlatex, Naturfett und Naturgerbstoffen hergestellt wird. Edel im Design, durch die umweltfreundliche Versiegelung extrem strapazierfähig, lässt sich mit diesem natürlichen Boden ein einzigartiges Ambiente gestalten.

LICO hat sein ganzes Wissen und die langjährige Erfahrung in diesen sinnlichen Fertigboden einfließen lassen, um das persönliche Empfinden von Eleganz, Wärme und Gefühl der Menschen zu steigern.

### Refined and innovative, with a beautiful design

The leather floating floor from LICO is a leather fibre produced from genuine, recycled, chrome-free leather, natural latex, natural oils and natural tanning agents. With its elegant design and its extreme durability thanks to its environmentally friendly sealing, this natural flooring enables you to create an unique ambience.

LICO has invested all its know-how and many years of experience in this sensual floating floor to enhance people's personal sense of elegance, warmth and feeling.

Cognac



Tobacco



Clube



7PL2306 Boa Silver / Boa Silver

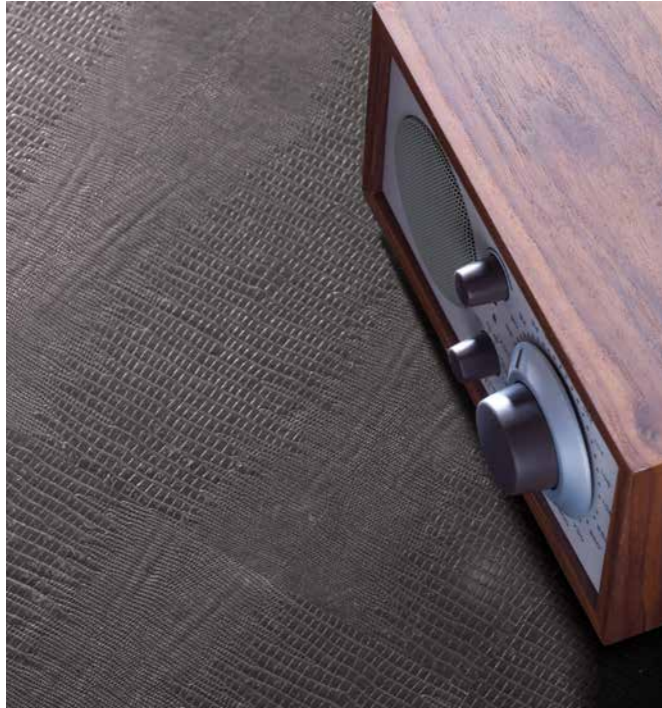

7PL2305 Boa Sand / Boa Sand



7PL2003 Mamba Sand / Mamba Sand



7PL41/119 Waran Beige / Waran Beige



7PL2101 Toro Chocco / Toro Chocco



7PL2102 Toro Bordeaux / Toro Bordeaux



7PL27 Cobra Bordeaux / Cobra Bordeaux



7PL2302 Boa Oxyd / Boa Oxyd



7PL2301 Boa Exotic / Boa Exotic



7PL9 Buffalo Mocca / Buffalo Mocca



7PL2306 Boa Silver / Boa Silver



Klasse / Class 23 / 32  
Klasse / Class 23 / 32



Naturprodukt  
Natural product



Lichtechtheit >7  
Lightfastness >7



Pflegeleicht  
Easy to care

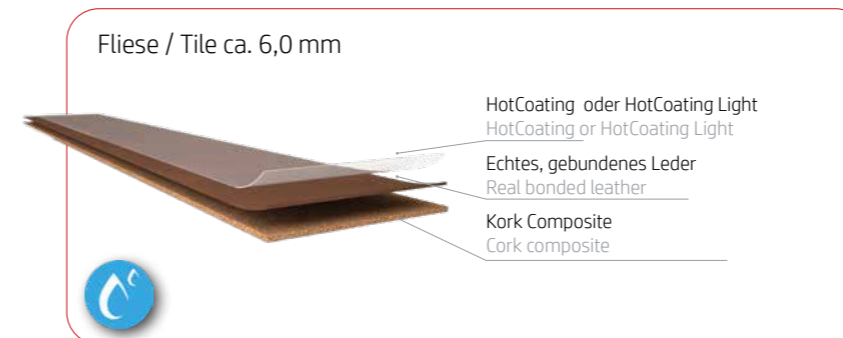
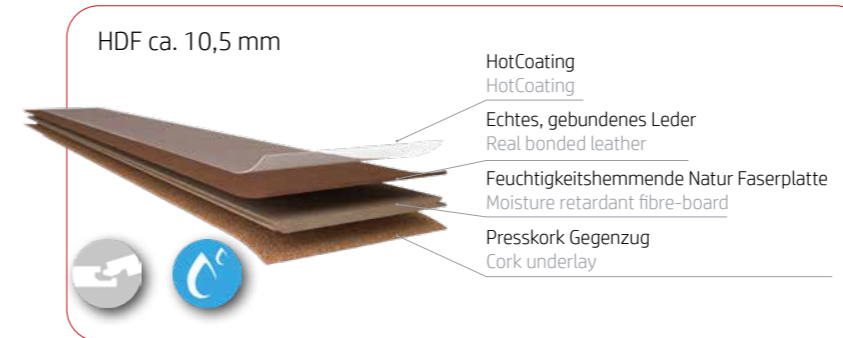

Fusswarm  
Warm to the touch



Chromfreies Leder  
Chrome free leather



Schall- und Trittschallisolierung  
Sound impact and phonic insulation



Verwendung nachwachsender Rohstoffe  
Use of regrowing raw material



Wärmeisolierend  
Thermal insulation



Gelenkschonend  
Soft to the tread

Buffalo Mocca / Buffalo Mocca



Formate / Dimensions

915 x 305 mm

620 x 450 mm





80003 Glimmerschiefer Verde Gris  
Mica Slate Verde Gris

## REALSTONE

### Echter Naturschiefer

In LICO Realstone vereinen sich die Vorteile von robustem und ästhetischem Naturstein mit denen von leisem und warmen Kork. Die Natursteinoberfläche in ihren verschiedenen, einzigartigen Schieferfarben (Schiefer und Glimmerschiefer) macht jeden Raum zum Unikat und dank der natürlichen Stein-Struktur zu einem Erlebnis für die Sinne.

### Real natural slate

LICO Realstone combines the advantages of robust and aesthetic natural stone with those of quiet and warm cork. The natural stone surface in its different, unique slate colors (slate and mica slate) makes every room unique and, thanks to the natural stone structure, an experience for the senses.

Klasse / Class 23 / 31  
Klasse / Class 23 / 31

Naturprodukt  
Natural product

Fussbodenheizung  
Underfloor heating

Pflegeleicht  
Easy to care

Strukturierte Oberfläche  
Structured surface

80001 Glimmerschiefer Auro  
Mica Slate Auro



80003 Glimmerschiefer Verde Gris  
Mica Slate Verde Gris



80503 Schiefer Arcobaleno Color  
Slate Arcobaleno Color



80001 Glimmerschiefer Auro  
Mica Slate Auro



80001 Glimmerschiefer Auro Mica Slate Auro



HDF ca. 11,0 mm

- Naturöl Imprägnierung  
Natural oil impregnation
- Echter Stein / Naturschiefer  
Real stone / natural slate
- Kork Composite  
Cork Composite
- Feuchtigkeitshemmende Natur Faserplatte  
Moisture retardant fibre-board
- Presskork Gegenzug  
Cork underlay

Fliese / Tile ca. 3,0 mm

- Naturöl Imprägnierung  
Natural oil impregnation
- Echter Stein / Naturschiefer  
Real stone / natural slate
- Kork Composite  
Cork Composite

- Fusswarm**  
Warm to the touch
- Antistatisch**  
Antistatic
- Schall- und Trittschallisierung**  
Sound impact and phonic insulation
- Verwendung nachwachsender Rohstoffe**  
Use of regrowing raw material
- Wärmeisolierend**  
Thermal insulation
- Gelenkschonend**  
Soft to the tread



Formate / Dimensions

1235 x 305 mm



Kork  
Printcork  
Lino  
Fibrano  
Ledo  
Realstone  
Real DesignWood  
Micodur  
Vinyl  
Hydro Fix  
Vintex Fix  
Eco Design  
Lipur  
Zubehör  
Lico Wall



## REAL DESIGNWOOD

### Der robuste Echtholzboden

Der Echtholzboden überzeugt mit natürlichen Designs und einer noch nie dagewesenen Strapazierfähigkeit bei einem Holzboden. Das Naturprodukt ist pflegeleicht und erfüllt die Brandklasse CflS1, ist somit geeignet für den Wohnbereich, als auch für den Objektbereich. Real DesignWood erfüllt alle Anforderungen der Nutzungsklasse 33 nach EN16511.

Neben den Natur-Designs besteht durch den optional einsetzbaren Digitaldruck die Möglichkeit, auch jeden noch so ausgefallenen Designwunsch zu erfüllen.

### The durable realwood floor

The real wood floor impresses with natural designs and with a unique durability by a wooden floor. This natural product is easy to clean and comply fire classification CflS1, thus is suitable for the living area, as well as for the commercial sector. Real Wood Design meets all requirements of Class 33 according to EN16511. In addition to the standard designs it's also possible (through the optional usable digital printing technology) to create personalized floors.

Eiche Klassik & 201447 Native / Oak Classic & 201447 Native

Eiche Weiss / Oak White



Eiche Creme / Oak Creme



Eiche Grau / Oak Grey



Eiche Sand / Oak Sand



Eiche Mocca / Oak Mocca



Eiche Klassik / Oak Classic



Eiche Coffee / Oak Coffee



Eiche Cherry / Oak Cherry



Eiche Chocco / Oak Chocco



Eiche Klassik - 201447 Native / Oak Classic - 201447 Native



Eiche Anthrazit / Oak Anthracite



201332 Abstract stars



Eiche Creme / Oak Creme



Klasse / Class 23 / 33  
Klasse / Class 23 / 33



Naturprodukt  
Natural product



2nd life



Extrem strapazierfähig  
Extremely durable



Resteindruck  
Residual Indentation

Real Designwood ca. 9,6 mm



HotCoating Beschichtung  
HotCoating protection

Echtholz  
Real wood

Feuchtigkeitshemmende Natur Faserplatte  
Moisture retardant fibre-board

Echtholz Gegenzug  
Real wood backing

Kork Trittschall  
Cork underlay



**Cfl-s1 Brandverhalten**  
Cfl-s1 Reaction to fire



**Fusswarm**  
Warm to the touch



**Echtholzoberfläche**  
Real wood surface



**Schall- und Trittschallisolierung**  
Sound impact and phonic insulation



**Verwendung nachwachsender Rohstoffe**  
Use of regrowing raw material



**Pflegeleicht**  
Easy to care



**Splitterfrei**  
Splinter free

Eiche Weiss / Oak White



Formate / Dimensions

1235 x 230 mm

Optional  
1235 x 230 mm

Designvielfalt dank Digitaldruck Technologie  
Design variety thanks to digital printing technology



Produced under license of Unilin - EP nr. 0843763/US, patent nr. 6.006.486





MICODUR - 201300 Stone Brown

## MICODUR

### Das Naturphänomen

Das Besondere an Micodur ist die gelungene Kombination einer vollkommen massstabilen mineralischen Trägerplatte und die Möglichkeiten der KORUS Oberflächentechnologie. Dies - gepaart mit der optischen Gestaltungsvielfalt der neuesten Digitaldrucktechnologie macht Micodur zum idealen Bodenbelag in beinahe allen Bereichen. Vom gesamten Wohnbereich bis hin zum hochstrapazierten Objektbereich.

Micodur ist die gelungene Alternative zu Kunststoff-, Holzwerkstoff-, oder Keramikböden und das im vollkommenen Einklang mit der Natur. Überzeugend sind die extrem positiven technischen Eigenschaften

### The natural phenomenon

Micodur is the successful combination of a perfectly stable mineral core board and the optical design variety of the newest digital printing technology.

Coupled with the properties of the KORUS surface technology, Micodur is suitable for almost every area. From the living area to highly frequented commercial Areas - Micodur is the alternative to plastic wood based or ceramic flooring and always in perfect harmony with nature. The remarkable technical features are totally convincing.



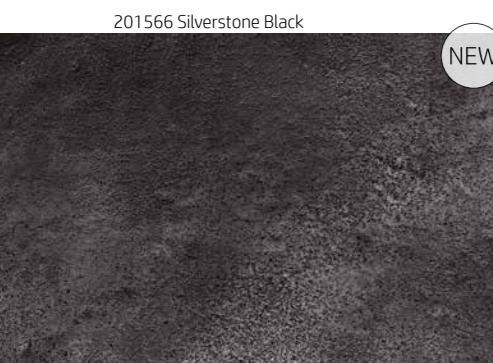

Kork

Printcork

Lino

Fibrano

Ledo

Realstone

Real DesignWood

Micodur

Vinyl

Hydro Fix

Vintex Fix

Eco Design

Lipur

Zubehör

Lico Wall

201421 Eiche Como Weiss / Oak Como White



201407 Eiche Como Light / Oak Como Light



201550 Northern Oak Sand



201493 Eiche Dakota / Oak Dakota



200611 Japanische Eiche Sägerau / Japanese Oak Craggy



201647 Eiche Timeless Hellbraun / Oak Timeless Lightbrown



201646 Eiche Timeless Grau / Oak Timeless Grey



201645 American Red Pine



201016 Eiche Olive Geräuchert / Oak Olive Flamed



201624 Eiche Savannah Ocker / Oak Savannah Ochre



201623 Savannah Eiche Dunkelgrau / Savannah Oak Darkgrey



201641 Savannah Eiche Cedar / Savannah Oak Cedar



200611 Japanische Eiche Sägerau / Japanese Oak Craggy



Klasse / Class 23 / 33  
Klasse / Class 23 / 33

Naturprodukt  
Natural product

2nd life

Dimensionsstabil  
Dimensionally stable

Wasserfest  
Waterproof



- Strapazierfähig**  
Durable
- Unendliche Designvielfalt**  
Designs at infinitum
- Schall- und Trittschallisolierung**  
Sound impact and phonic insulation
- Verwendung nachwachsender Rohstoffe**  
Use of regrowing raw material
- Wärmeisolierend**  
Thermal insulation
- Microfase**  
Micro bevel
- Lichtechtheit >7**  
Light fastness >7
- A2fl-s1**  
A2fl-s1
- Bis zu 1000 m² ohne Trennfugen**  
Up to 1000 m² without separation joints

201108 Cement Graphite - Friseursalon in Deutschland / Hair Dresser Germany



Formate / Dimensions

920 x 460 mm

1235 x 200 mm



Kork  
Printcork  
Lino  
Fibrano  
Ledo  
Realstone  
RealDesignWood  
**Micodur**  
Vinyl  
Hydro Fix  
Vintex Fix  
Eco Design  
Lipur  
Zubehör  
Lico Wall



Vinyl Suisse Edition - Royal Oak Brown - 590-2

## VINYL

### Der Fertigboden für extreme Ansprüche

Durch das äusserst resistente Designvinyl ist dieser Fertigboden sehr widerstandsfähig gegen Verschleiss, Verschmutzung und ist zudem ausgesprochen pflegeleicht. LICO Vinyl präsentiert sich in einer unglaublich grossen Auswahl an Designs und Farben:

Von antiken Holzdielen über die klassische, eichenfarbene Holzstruktur bis hin zu modernen Dekoren mit Natursteinoptik. Durch die strukturierte Oberfläche wird eine naturnahe Haptik vermittelt.

Die Böden sind frei von Stoffen, die Menschen und Umwelt gefährden.

LICO Vinyl ist mit der Summe dieser Eigenschaften und seinem natürlichen Look der ideale Bodenbelag in allen Bereichen, in denen hohe Belastbarkeit mit besonderem Design kombiniert werden soll.

### The floating floor for extrem requirement

This floating floor with vinyl top layer is extremely scratch-resistant, dirt-proof and really easy to maintain.

It is available in a wide range of designs and colors: From antique wood planks to the classic, oak-colored wood texture and modern decors with a natural stone look. The structured surface conveys a natural haptic.

Our floors are completely environment-friendly and are free of harmful substances for nature or people.

All these characteristics combined with the natural look of LICO vinyl make it the ideal flooring in all areas that require a high level of resilience paired with a special design.

# VINYL ECONOMY PLUS

Der Fertigboden für extreme Ansprüche  
The floating floor for extrem requirement



6501-A Lärche Geräuchert / Larch Smoked

6398-A Deutsche Eiche Weiss / German Oak White



10108-1 Weisskiefer Rustikal / Pine White Rustical



6397-A Waldahorn / Maple Forest



10205-1 Berglärche Gekalkt / Mountain Larch Limewashed



55309 Eiche Klassisch / Oak Classic



6398-B Deutsche Eiche / German Oak



6501-A Lärche Geräuchert / Larch Smoked



10109-1 Berglärche Natur / Mountain Larch Nature



10118-1 Nuss Rustikal / Walnut Rustical



10204-2 Eiche Dunkel Rustikal / Oak Dark Rustical



6398-B Deutsche Eiche / German Oak





Klasse / Class 23 / 32  
Klasse / Class 23 / 32



Phthalatfrei  
Phthalatefree



Lichtechtheit >6  
Lightfastness >6



Fußbodenheizung  
Underfloor heating



Pflegeleicht  
Easy to care

HDF ca. 9,5 mm



Hochstrapazierfähige PU Beschichtung  
Hardwearing PU Protection

Vinyl  
Vinyl

Feuchtigkeitshemmende Natur Faserplatte  
Moisture retardant fibre-board

Presskork Gegenzug  
Cork underlay



Fusswarm  
Warm to the touch



Strapazierfähig  
Durable



Schall- und Trittschallisierung  
Sound impact and phonic insulation

NEW Hydrowood ca. 9,5 mm



Hochstrapazierfähige PU Beschichtung  
Hardwearing PU Protection

Vinyl  
Vinyl

Wasserfeste Holzwerkstoff-Trägerplatte  
Waterproof wood based board

Presskork Gegenzug  
Cork underlay



Antistatisch  
Antistatic



Wärmeisolierend  
Thermal insulation



Gelenkschonend  
Soft to the tread

Hydro Sound ca. 6,2 mm



Hochstrapazierfähige PU Beschichtung  
Hardwearing PU Protection

Vinyl  
Vinyl

Wasserfeste Hydro Trägerplatte  
Waterproof hydro core board

Hydrosound Gegenzug  
Hydrosound underlay

Fliese / Tile ca. 1,5 mm



Hochstrapazierfähige PU Beschichtung  
Hardwearing PU Protection

Vinyl  
Vinyl

Formate / Dimensions

1235 x 230 mm

1235 x 305 mm

# VINYL DESIGN 16

Der Fertigboden für extreme Ansprüche  
The floating floor for extrem requirement

VINYL DESIGN 16  
Der Fertigboden für extreme Ansprüche  
The floating floor for extrem requirement



160701 Persische Eiche Gebleicht / Persian Oak Bleached



1122 Kernbuche Weiss / Core Beech White



70210 Persische Eiche Gekalkt / Persian Oak Limewashed



1123-1 Weisseiche Polar / White Oak Polar



1123 Weisseiche Sand / White Oak Sand



70208 Persische Eiche Geräuchert / Persian Oak Smoked



1122-2 Walnuss / Walnut



1124-1 Buscheiche Geräuchert / Bush Oak Smoked



70012 Waldkiefer / Wood Pine



3651AB-1 Schindeleiche / Shingle Oak



61109 Bergkiefer / Mountain Pine



1122-1 Kernbuche / Core Beech



1087-1 Honigeiche / Honey Oak



1087-1 Honigeiche / Honey Oak



1124-2 Buscheiche / Bush Oak



83801 Seekiefer / Sea Pine



1133 Rio Palisander



- Fusswarm**  
Warm to the touch
- Strapazierfähig**  
Durable
- Schall- und Trittschallisolierung**  
Sound impact and phonic insulation
- Antistatisch**  
Antistatic
- Wärmeisolierend**  
Thermal insulation
- Gelenkschonend**  
Soft to the tread

## Formate / Dimensions

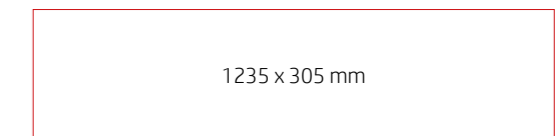
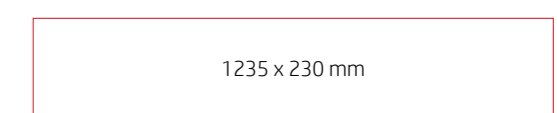

Kork  
Printcork  
Lino  
Fibrano  
Ledo  
Realstone  
RealDesignWood  
RealDesignWood  
Micodur  
Vinyl  
Hydro Fix  
Hydro Fix  
Vintex Fix  
Eco Design  
Lipur  
Zubehör  
Lico Wall

# VINYL DESIGN PLUS

Der Fertigboden für extreme Ansprüche  
The floating floor for extrem requirement

VINYL DESIGN PLUS  
Der Fertigboden für extreme Ansprüche  
The floating floor for extrem requirement



54802 Bergfichte Weiss / Mountain Spruce White



8242-11 Perleiche Gekalkt / Pearl Oak Limewashed



56018 Eiche Gekalkt / Oak Limewashed



53030 Apfelbaum / Apple Tree



82048-4 Eiche Traditional / Oak Traditional



1041-1 Eiche Astig / Knotty Oak



56153 Birke gealtert / Birk Old



53008 Alte Fichte Natur / Old Spruce Nature



53010 Alte Fichte Geräuchert / Old Spruce Smoked



56018 Eiche Gekalkt / Oak Limewashed

HDF ca. 9,8 mm

- Hochstrapazierfähige PU Beschichtung  
Hardwearing PU Protection
- Vinyl
- Vinyl
- Feuchtigkeitshemmende Natur Faserplatte  
Moisture retardant fibre-board
- Presskork Gegenzug  
Cork underlay

**NEW** Hydrowood ca. 9,8 mm

- Hochstrapazierfähige PU Beschichtung  
Hardwearing PU Protection
- Vinyl
- Vinyl
- Wasserfeste Holzwerkstoff-Trägerplatte  
Waterproof wood based board
- Presskork Gegenzug  
Cork underlay

Hydro Sound ca. 6,5 mm

- Hochstrapazierfähige PU Beschichtung  
Hardwearing PU Protection
- Vinyl
- Vinyl
- Wasserfeste Hydro Trägerplatte  
Waterproof hydro core board
- Hydrosound Gegenzug  
Hydrosound underlay

Fliese / Tile ca. 1,8 mm

- Hochstrapazierfähige PU Beschichtung  
Hardwearing PU Protection
- Vinyl
- Vinyl

- Fusswarm**  
Warm to the touch
- Strapazierfähig**  
Durable
- Schall- und Trittschallisierung**  
Sound impact and phonic insulation
- Antistatisch**  
Antistatic
- Wärmeisolierend**  
Thermal insulation
- Gelenkschonend**  
Soft to the tread

## Formate / Dimensions

- 1235 x 230 mm
- 1235 x 305 mm



Kork

Printcork

Lino

Fibrano

Ledo

Realstone

Real DesignWood

Real DesignWood

Micodur

Vinyl

Hydro Fix

Vintex Fix

Eco Design

Lipur

Zubehör

Lico Wall

Lico Wall

59

58

# VINYL SUISSE EDITION

Design das beeindruckt  
Design to impress

VINYL SUISSE EDITION  
Design das Beeindruckt  
Design to impress



590-7 Royal Oak Light



590-15 Royal Oak Dark



590-5 Royal Oak Grey



590-2 Royal Oak Brown



590-4 Royal Oak Natural



590-7 Royal Oak Light



590-3 Royal Oak White



Klasse / Class 23 / 32  
Klasse / Class 23 / 32



Phthalatfrei  
Phthalatefree



Lichtechtheit >6  
Lightfastness >6



Fußbodenheizung  
Underfloor heating



Pflegeleicht  
Easy to care

**HDF ca. 9,8 mm**

- Hochstrapazierfähige PU Beschichtung  
Hardwearing PU Protection
- Vinyl  
Vinyl
- Feuchtigkeitshemmende Natur Faserplatte  
Moisture retardant fibre-board
- Presskork Gegenzug  
Cork underlay

**NEW Hydrowood ca. 9,8 mm**

- Hochstrapazierfähige PU Beschichtung  
Hardwearing PU Protection
- Vinyl  
Vinyl
- Wasserfeste Holzwerkstoff-Trägerplatte  
Waterproof wood based board
- Presskork Gegenzug  
Cork underlay

**Hydro Sound ca. 6,5 mm**

- Hochstrapazierfähige PU Beschichtung  
Hardwearing PU Protection
- Vinyl  
Vinyl
- Wasserfeste Hydro Trägerplatte  
Waterproof hydro core board
- Hydrosound Gegenzug  
Hydrosound underlay

**Fliese / Tile ca. 1,8 mm**

- Hochstrapazierfähige PU Beschichtung  
Hardwearing PU Protection
- Vinyl  
Vinyl

- Fusswarm**  
Warm to the touch
- Strapazierfähig**  
Durable
- Schall- und Trittschallisolierung**  
Sound impact and phonic insulation
- Antistatisch**  
Antistatic
- Wärmeisolierend**  
Thermal insulation
- Gelenkschonend**  
Soft to the tread

## Formate / Dimensions

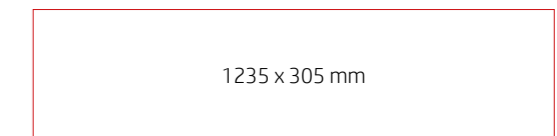
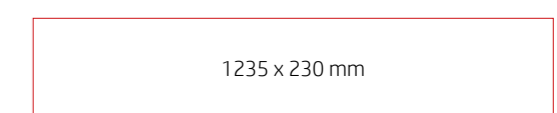

Kork  
Printcork  
Lino  
Fibrano  
Ledo  
Realstone  
Real DesignWood  
Micodur  
Vinyl  
Hydro Fix  
Vintex Fix  
Eco Design  
Lipur  
Zubehör  
Lico Wall



# VINYL DESIGN 21

Design das beeindruckt  
Design to impress

VINYL DESIGN 21  
Design das Beeindruckt  
Design to impress



21006 Herbsteiche Creme / Autumn Oak Creme

21004 Eiche Umbra / Oak Umber



21003 Eiche Highlands / Oak Highlands



21007 Herbsteiche / Autumn Oak



21006 Herbsteiche Creme / Autumn Oak Creme



21002 Wüstenahorn / Desert Maple



21001 Lotuseiche / Lotus Oak



21005 Eiche Dakota / Oak Dakota



21008 Nebeliche / Fog Oak



Klasse / Class 23 / 32  
Klasse / Class 23 / 32

Phthalatfrei  
Phthalatefree

Lichtechtheit >6  
Lightfastness >6

Fußbodenheizung  
Underfloor heating

Pflegeleicht  
Easy to care

HDF ca. 9,5 mm

Hochstrapazierfähige PU Beschichtung  
Hardwearing PU Protection

Vinyl  
Vinyl

Feuchtigkeitshemmende Natur Faserplatte  
Moisture retardant fibre-board

Presskork Gegenzug  
Cork underlay

**NEW** Hydrowood ca. 9,5 mm

Hochstrapazierfähige PU Beschichtung  
Hardwearing PU Protection

Vinyl  
Vinyl

Wasserfeste Holzwerkstoff-Trägerplatte  
Waterproof wood based board

Presskork Gegenzug  
Cork underlay

Hydro Sound ca. 6,2 mm

Hochstrapazierfähige PU Beschichtung  
Hardwearing PU Protection

Vinyl  
Vinyl

Wasserfeste Hydro Trägerplatte  
Waterproof hydro core board

Hydrosound Gegenzug  
Hydrosound underlay

Fliese / Tile ca. 2,5 mm

Hochstrapazierfähige PU Beschichtung  
Hardwearing PU Protection

Vinyl  
Vinyl

- Fusswarm**  
Warm to the touch
- Strapazierfähig**  
Durable
- Schall- und Trittschallsolierung**  
Sound impact and phonic insulation
- Antistatisch**  
Antistatic
- Wärmeisolierend**  
Thermal insulation
- Gelenkschonend**  
Soft to the tread

Formate / Dimensions

1235 x 230 mm

1235 x 305 mm



Kork  
Printcork  
Lino  
Fibrano  
Ledo  
Realstone  
Real DesignWood  
Real DesignWood  
Micodur  
Vinyl  
Hydro Fix  
Vintex Fix  
Eco Design  
Lipur  
Zubehör  
Lico Wall



# VINYL OBJEKT

Der Fertigboden für extreme Ansprüche  
The floating floor for extrem requirement

8390-1 Lärche Zermatt / Larch Zermatt



# VINYL OBJEKT

Der Fertigboden für extreme Ansprüche  
The floating floor for extrem requirement



Klasse / Class 23 / 33  
Klasse / Class 23 / 33



Phthalatfrei  
Phthalatefree



Lichtechtheit >6  
Lightfastness >6



Fußbodenheizung  
Underfloor heating



Pflegeleicht  
Easy to care

HDF ca. 10,0 mm



Hochstrapazierfähige PU Beschichtung  
Hardwearing PU Protection

Vinyl  
Vinyl

Feuchtigkeitshemmende Natur Faserplatte  
Moisture retardant fibre-board

Presskork Gegenzug  
Cork underlay



NEW Hydrowood ca. 10,0 mm



Hochstrapazierfähige PU Beschichtung  
Hardwearing PU Protection

Vinyl  
Vinyl

Wasserfeste Holzwerkstoff-Trägerplatte  
Waterproof wood based board

Presskork Gegenzug  
Cork underlay



Hydro Sound ca. 6,7 mm



Hochstrapazierfähige PU Beschichtung  
Hardwearing PU Protection

Vinyl  
Vinyl

Wasserfeste Hydro Trägerplatte  
Waterproof hydro core board

Hydrosound Gegenzug  
Hydrosound underlay



Fliese / Tile ca. 2,0 mm



Hochstrapazierfähige PU Beschichtung  
Hardwearing PU Protection

Vinyl  
Vinyl



Fusswarm  
Warm to the touch



Strapazierfähig  
Durable



Schall- und Trittschallsolierung  
Sound impact and phonic insulation



Antistatisch  
Antistatic



Wärmeisolierend  
Thermal insulation



Gelenkschonend  
Soft to the tread

Formate / Dimensions

1235 x 230 mm

1235 x 305 mm



Kork

Printcork

Lino

Fibrano

Ledo

Realstone

Real DesignWood

Real DesignWood

Micodur

Vinyl

Hydro Fix

Hydro Fix

Eco Design

Lipur

Zubehör

Lico Wall

66

67

# VINYL OBJEKT SYNCRO

Der Fertigboden für extreme Ansprüche  
The floating floor for extrem requirement

VINYL OBJEKT SYNCRO  
Der Fertigboden für extreme Ansprüche  
The floating floor for extrem requirement



22008 Cognaceiche Hell / Coagnac Oak Light

Klasse / Class 23 / 33  
Klasse / Class 23 / 33

Phthalatfrei  
Phthalatefree

Lichtechtheit >6  
Lightfastness >6

Fußbodenheizung  
Underfloor heating

Pflegeleicht  
Easy to care

HDF ca. 10,0 mm

Hochstrapazierfähige PU Beschichtung  
Hardwearing PU Protection

Vinyl  
Vinyl

Feuchtigkeitshemmende Natur Faserplatte  
Moisture retardant fibre-board

Presskork Gegenzug  
Cork underlay

NEW Hydrowood ca. 10,0 mm

Hochstrapazierfähige PU Beschichtung  
Hardwearing PU Protection

Vinyl  
Vinyl

Wasserfeste Holzwerkstoff-Trägerplatte  
Waterproof wood based board

Presskork Gegenzug  
Cork underlay

Hydro Sound ca. 6,7 mm

Hochstrapazierfähige PU Beschichtung  
Hardwearing PU Protection

Vinyl  
Vinyl

Wasserfeste Hydro Trägerplatte  
Waterproof hydro core board

Hydrosound Gegenzug  
Hydrosound underlay

Fliese / Tile ca. 2,0 mm

Hochstrapazierfähige PU Beschichtung  
Hardwearing PU Protection

Vinyl  
Vinyl

- Fusswarm**  
Warm to the touch
- Strapazierfähig**  
Durable
- Schall- und Trittschallisolierung**  
Sound impact and phonic insulation
- Antistatisch**  
Antistatic
- Wärmeisolierend**  
Thermal insulation
- Gelenkschonend**  
Soft to the tread

22006 Eiche Levante Mocca / Oak Levante Mocca	22007 Cognaceiche Natur / Cognac Oak Nature
22005 Eiche Levante Platin / Oak Levante Platinum	22002 Canyoneiche Braun / Canyon Oak Brown
22004 Eiche Levante Grau / Oak Levante Grey	22008 Cognaceiche Hell / Coagnac Oak Light
22003 Eiche Levante Creme / Oak Levante Creme	22001 Canyoneiche Sand / Canyon Oak Sand

Formate / Dimensions

1235 x 230 mm

1235 x 305 mm

Kork  
Printcork  
Lino  
Fibrano  
Ledo  
Realstone  
Real DesignWood  
Real DesignWood  
Micodur  
Vinyl  
Hydro Fix  
Vintex Fix  
Eco Design  
Lipur  
Zubehör  
Lico Wall

2289-3 Concrete Loft Grey



NEW

2289-3 Beton Loft Grau / Concrete Loft Grey



23076-9 Monte Sasso



NEW

23076-9 Monte Sasso



43201 Cement Steel



56162 Cement Dark



38384 Kieselstein



3399 Schieferstein



4021-D02 Cement Iron



37289 Betonstein



72049 Metallic Black



37702 Slate Silver

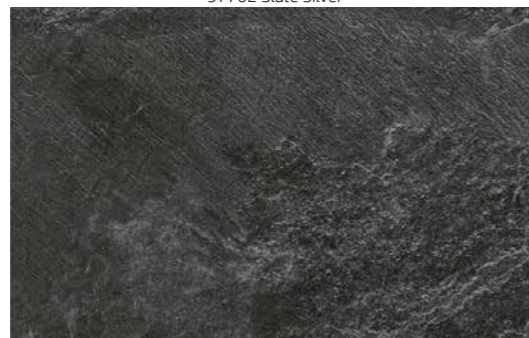

18-1 Black Stone



Kork

Printcork

Lino

Fibrano

Ledo

Realstone

Real DesignWood

Micodur

Vinyl

Hydro Fix

Vintex Fix

Eco Design

Lipur

Zubehör

Lico Wall



77102 Metallic Gold

55436 Neve

1039-6 Marmorstein



2376-3A Monte Sasso Creme

NEW

72019 Cement White

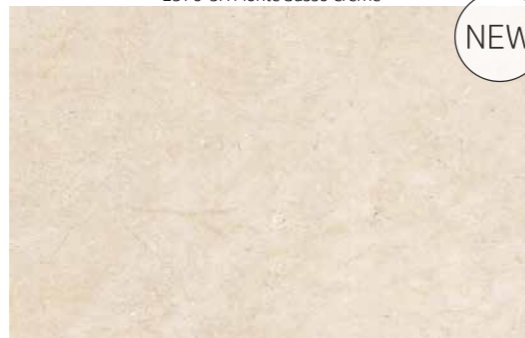

66908 Traverto

77802 Sandstone Grey



77102 Metallic Gold

3397-1 Cement Creme



67803 Cotto

23104-1 Persia

NEW

6451-9 Cement Copper



HDF ca. 10,0 mm



Hochstrapazierfähige PU Beschichtung  
Hardwearing PU Protection  
Vinyl  
Vinyl  
Feuchtigkeitshemmende Natur Faserplatte  
Moisture retardant fibre-board  
Presskork Gegenzug  
Cork underlay

NEW Hydrowood ca. 10,0 mm



Hochstrapazierfähige PU Beschichtung  
Hardwearing PU Protection  
Vinyl  
Vinyl  
Wasserfeste Holzwerkstoff-Trägerplatte  
Waterproof wood based board  
Presskork Gegenzug  
Cork underlay

Hydro Sound ca. 6,7 mm



Hochstrapazierfähige PU Beschichtung  
Hardwearing PU Protection  
Vinyl  
Vinyl  
Wasserfeste Hydro Trägerplatte  
Waterproof hydro core board  
Hydrosound Gegenzug  
Hydrosound underlay

Fliese / Tile ca. 2,0 mm



Hochstrapazierfähige PU Beschichtung  
Hardwearing PU Protection  
Vinyl  
Vinyl

- Fusswarm**  
Warm to the touch
- Strapazierfähig**  
Durable
- Schall- und Trittschallisierung**  
Sound impact and phonic insulation
- Antistatisch**  
Antistatic
- Wärmeisolierend**  
Thermal insulation
- Gelenkschonend**  
Soft to the tread

Formate / Dimensions

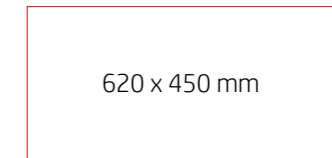
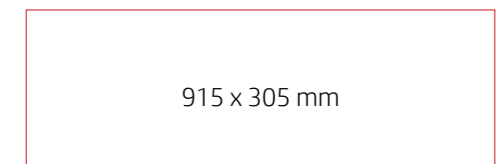

Kork  
Printcork  
Lino  
Fibrano  
Ledo  
Realstone  
RealDesignWood  
Real  
Micodur  
Vinyl  
Hydro Fix  
Vintex Fix  
Eco Design  
Lipur  
Zubehör  
Lico Wall



# VINYL LONGUS

Der Fertigboden für extreme Ansprüche  
The floating floor for extrem requirement

21004 Eiche Umbra / Oak Umber



# VINYL LONGUS

Der Fertigboden für extreme Ansprüche  
The floating floor for extrem requirement



Klasse / Class 23 / 33  
Klasse / Class 23 / 33



Phthalatfrei  
Phthalatefree



Lichtechtheit >6  
Lightfastness >6



Fußbodenheizung  
Underfloor heating



Pflegeleicht  
Easy to care

HDF ca. 10,0 mm



Hochstrapazierfähige PU Beschichtung  
Hardwearing PU Protection

Vinyl  
Vinyl

Feuchtigkeithemmende Natur Faserplatte  
Moisture retardant fibre-board

Presskork Gegenzug  
Cork underlay



NEW Hydrowood ca. 10,0 mm



Hochstrapazierfähige PU Beschichtung  
Hardwearing PU Protection

Vinyl  
Vinyl

Wasserfeste Holzwerkstoff-Trägerplatte  
Waterproof wood based board

Presskork Gegenzug  
Cork underlay



Fliese / Tile ca. 2,0 mm



Hochstrapazierfähige PU Beschichtung  
Hardwearing PU Protection

Vinyl  
Vinyl



Formate / Dimensions

1815 X 230 mm

**XL**

1815 x 305 mm

**XL**



Kork

Printcork

Lino

Fibrano

Ledo

Realstone

Real DesignWood

Real DesignWood

Micodur

Vinyl

Hydro Fix

Vintex Fix

Eco Design

Lipur

Zubehör

Lico Wall





590-4 Royal Oak Natural

## HYDRO FIX

### Der smarte Designboden

Hydro Fix ist der wasserfeste, äußerst resistente Designboden mit integriertem Trittschall.

Seine geringe Aufbauhöhe und sein modernes Holz- und Steindesign überzeugt in ganzer Linie. Weiters kann Hydro Fix durch seine naturnahe Haptik und durch die strukturierte Oberfläche punkten.

Die Wasserfestigkeit, die sehr hohe Massstabilität unter Temperatureinwirkung und die hohe Belastbarkeit machen den Designboden für alle Bereiche interessant. Besonders hervorzuheben ist der integrierte Trittschall und die elastische Zwischenlage. Diese unterstreichen einen angenehmen Gehkomfort und unterscheiden Hydro Fix maßgeblich von anderen Produkten.

### The smart design floor

Hydro Fix is the waterproof, highly resistant design floor with integrated impact sound.

Its modern wood and stone design and low construction thickness are convincing throughout. Furthermore, Hydro Fix can score with natural touch and structured surface.

The water resistance, the very high dimensional stability under temperature change and the high durability make the design floor interesting for all areas. Particularly noteworthy is the integrated impact sound and the elastic intermediate layer. These underline a pleasant walking comfort and distinguish Hydro Fix significantly from other products.



1087-1 Honigeiche / Honey Oak



				
Klasse / Class 23 / 32 Klasse / Class 23 / 32	Phthalatfrei Phthalatefree	Lichtechtheit >6 Lightfastness >6	Fußbodenheizung Underfloor heating	Wasserfest Waterproof

**Hydro Fix ca. 5,5 mm**









- Hochstrapazierfähige PU Beschichtung  
Hardwearing PU Protection
- Nutzschicht  
Wear layer
- Dekorfolie  
Decorative film
- Elastische Zwischenlage  
Elastic backing
- Wasserfeste Hydro Trägerplatte  
Waterproof hydro core board
- Wasserfester Trittschall Gegenzug  
Waterproof sound underlay

**Hydro Fix S ca. 5,4 mm**



- Hochstrapazierfähige PU Beschichtung  
Hardwearing PU Protection
- Nutzschicht  
Wear layer
- Dekorfolie  
Decorative film
- Wasserfeste Hydro Trägerplatte  
Waterproof hydro core board
- Wasserfester Trittschall Gegenzug  
Waterproof sound underlay

-  **Fusswarm**  
Warm to the touch
-  **Strapazierfähig**  
Durable
-  **Schall- und Trittschallisolierung**  
Sound impact and phonic insulation
-  **Antistatisch**  
Antistatic
-  **Wärmeisolierend**  
Thermal insulation
-  **Gelenkschonend**  
Soft to the tread

6386-3 Bergkastanie / Mountain Chestnut



Formate / Dimensions

1235 x 230 mm

1235 x 305 mm







- Kork
- Printcork
- Lino
- Fibrano
- Ledo
- Realstone
- RealDesignWood
- RealDesignWood
- Micodur
- Vinyl
- Hydro Fix**
- Vintex Fix
- Eco Design
- Lipur
- Zubehör
- Lico Wall

# HYDRO FIX OBJEKT

Der smarte Designboden  
The smart design floor

190L-04 Eiche Davos / Oak Davos



637L-03 Eiche Emmen / Oak Emmen



8176-4 Eiche Uster / Oak Uster



6311-2 Eiche Locarno / Oak Locarno



190L-04 Eiche Davos / Oak Davos



8390-1 Lärche Zermatt / Larch Zermatt



637L-07 Eiche Münstair / Oak Münstair



12591-4 Kiefer Zug / Pine Zug



8103-2 Eiche St. Gallen / Oak St. Gallen



191-08 Altholz Sitten / Old Wood Sitten



3651AB-1 Schindeleiche / Shingle Oak



619-01 Kiefer Risch / Pine Risch



179-02 Eiche Brugg / Oak Brugg



8390-8 Lärche Kloten / Larch Kloten



8176-1 Eiche Chur / Oak Chur



191-01 Altholz Thun / Old Wood Thun



9013-7 Eiche Luzern / Oak Luzern



Kork

Printcork

Lino

Fibrano

Ledo

Realstone

RealDesignWood

Micodur

Vinyl

**Hydro Fix**

Vintex Fix

Eco Design

Lipur

Zubehör

Lico Wall

23076-3A Monte Sasso Creme



2124-31 Beton Light / Cement Light



1039-6 S Marmorstein



23076-3A Monte Sasso Creme



949 Marmor Calacatta



38384 S Kieselstein



2289-3 Concrete Loft Grey



2124-31 Beton Light / Cement Light

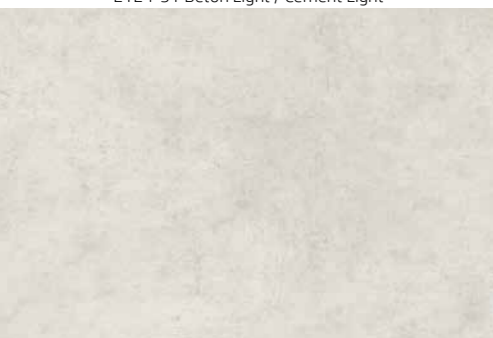

2124-32 Beton grau / Cement grau



3397-1 Beton Creme / Cement Creme



37289 S Betonstein



23076-9 Monte Sasso



23104-1 Persia



4021-D02 Beton Iron / Cement Iron



6451-9 Beton Kupfer / Cement Copper



1361-37 Beton Anthrazit / Cement Anthrazit



3399 S Schieferstein



Kork

Printcork

Lino

Fibrano

Ledo

Realstone

Real DesignWood

Micodur

Vinyl

Hydro Fix

Vintex Fix

Eco Design

Lipur

Zubehör

Lico Wall

4021-D02 Beton Iron / Cement Iron



Klasse / Class 23 / 33  
Klasse / Class 23 / 33



Phthalatfrei  
Phthalatefree



Lichtechtheit >6  
Lightfastness >6



Fußbodenheizung  
Underfloor heating



Wasserfest  
Waterproof



- Fusswarm**  
Warm to the touch
- Strapazierfähig**  
Durable
- Schall- und Trittschallisolierung**  
Sound impact and phonic insulation
- Antistatisch**  
Antistatic
- Wärmeisolierend**  
Thermal insulation
- Gelenkschonend**  
Soft to the tread



Formate / Dimensions

- 620 x 450 mm
- 1235 x 230 mm
- 1235 x 305 mm

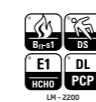

Kork  
Printcork  
Lino  
Fibrano  
Ledo  
Realstone  
RealDesignWood  
MicoDur  
Vinyl  
Hydro Fix  
Vintex Fix  
Eco Design  
Lipur  
Zubehör  
Lico Wall



## VINTEX FIX

### ... einzigartig und elastisch

Vintex Fix ist ein einzigartiger, elastischer Fertigboden mit textiler Webstruktur für den privaten sowie den Objekt-Bereich.

Der extrem widerstandsfähige Bodenbelag wurde jahrelang zur vollflächigen Verklebung verwendet und hat nun auch im Fertigbodenbereich Einzug gefunden.

Die Dekorstruktur wurde so konzipiert, dass die einzelnen Dielen nicht zu sehen sind, wobei der Vinylgarn gewebt und verschweisst ist. Dadurch entsteht der optische Eindruck einer durchgehenden Fläche. Der Pflege- und Reinigungsaufwand ist bei Vintex Fix sehr gering, auch die Reinigung mit einer Bürstreinigungsmaschine ist möglich.

Dank der 100 % wasserfesten Hydro Fix-Trägerplatte kann der Boden auch in Nassräumen verwendet werden.

### ... unique and elastic finished

Vintex Fix is an unique, elastic finished floor with a textile woven structure for the private as well as the commercial area. The extremely durable floor covering has been used for full surface bonding for years and has now found entrance to the finished flooring sector. The decorative structure has been designed that single floorboards are hardly visible, to achieve this the vinyl fabric has been woven and welded. This creates the visual impression of a continuous surface. The care and cleaning effort is very low, even cleaning with a brush cleaning machine is possible.

Thanks to the 100% waterproof coreboard, Vintex Fix can also be used in wet rooms.

8-06

# VINTEX FIX

... einzigartig und elastisch  
... unique and elastic finished

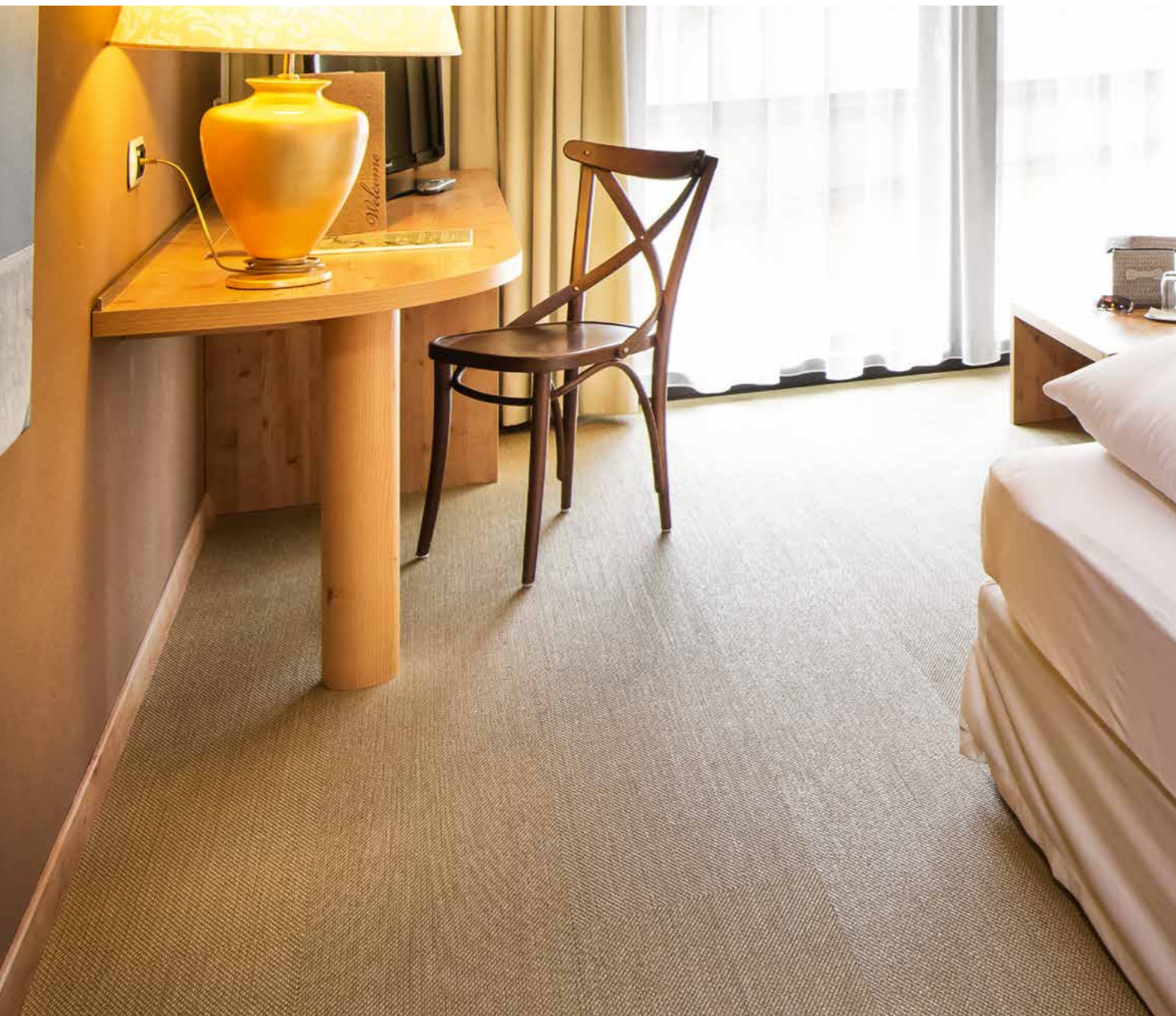

# VINTEX FIX

... einzigartig und elastisch  
... unique and elastic finished

Klasse / Class 23 / 33  
Klasse / Class 23 / 33

Strukturierte Oberfläche  
Structured surface

Lichtechtheit >7  
Lightfastness >7

Fußbodenheizung  
Underfloor heating

Wasserfest  
Waterproof



- Fusswarm**  
Warm to the touch
- Strapazierfähig**  
Durable
- Schall- und Trittschallisolierung**  
Sound impact and phonic insulation
- Antistatisch**  
Antistatic
- Wärmeisolierend**  
Thermal insulation
- Gelenkschonend**  
Soft to the tread

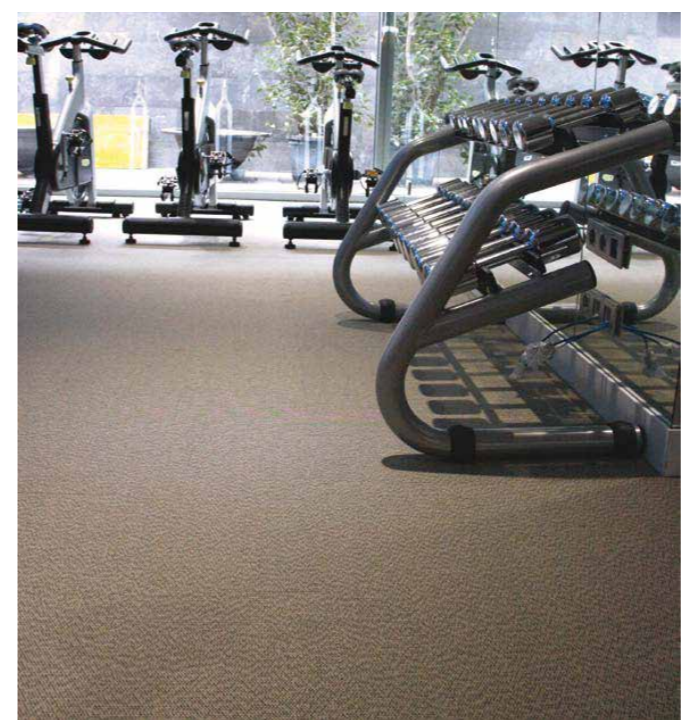

Formate / Dimensions

1235 x 305 mm



Kork  
Printcork  
Lino  
Fibrano  
Ledo  
Realstone  
Real DesignWood  
Microdur  
Vinyl  
Hydro Fix  
Vintex Fix  
Eco Design  
Lipur  
Zubehör  
Lico Wall





9825-02 Formwork

## ECO DESIGN

### Der PVC- freie Designboden

Eco Design ist ein innovativer Bodenbelag, welcher mit einer Reihe von Vorteilen zu überzeugen weiss. Eco Design ist vollständig PVC-frei, beinhaltet somit weder Chlor noch Weichmacher. Durch die Elektronenstrahl gehärtete Oberfläche weist der Bodenbelag eine hohe Strapazierfähigkeit auf.

Eco Design ist auch mit der wasserfesten Hydro - Trägerplatte erhältlich und ist in dieser Ausführung geeignet für Nassräume, Spa-Bereiche und vieles mehr.

### The PVC-free design floor

Eco Design is an innovative floor, which convinces with a lot of benefits. Eco Design is 100% PVC-free, therefore it does not contain neither chlorine nor plasticizer. Because of the electron beam hardened surface it shows a high durability.

Eco Design is also available with the waterproof Hydro-board. In this version it is suitable for wet rooms, spa areas and many more.

1938 Borstenfichte Natur / Bristle Spruce Nature



1845 Norwegische Eiseiche / Norwegian Ice Oak



1942 Amerikanische Rotfichte / American Red Spruce



1943 Fichte Weiss / Spruce White



191003-1 Canadian Oak Natural



9825-02 Formwork



1846 Norwegische Eiche Natur / Norwegian Oak Natural



191003-2 Canadian Oak Grey



1907 Serbische Fichte Natur / Serbian Spruce Nature



1941 Serbische Fichte Gekalkt / Serbian Spruce Limewashed



1843 Norwegische Eiche Dunkel / Norwegian Dark Oak



1844 Norwegische Eiche Gekalkt / Norwegian Oak Limewashed



1937 Schwarzfichte / Black Spruce



1939 Borstenfichte Grau / Bristle Spruce Grey



1940 Serbische Fichte Gerächt / Serbian Spruce Smoked



Klasse / Class 23 / 33  
Klasse / Class 23 / 33

**PVC FREE**  
100 % PVC frei  
100 % PVC free

Lichtechtheit >6  
Lightfastness >6

Geringe Aufbauhöhe  
Low height

Pflegeleicht  
Easy to care

**HDF Eco Design ca. 8,3 mm**

- Hochstrapazierfähige PU Beschichtung  
Hardwearing PU Protection
- PVC-freie Designauflage  
PVC-free design coverings
- Feuchtigkeitshemmende Natur Faserplatte  
Moisture retardant fibre-board
- Presskork Gegenzug  
Cork underlay

**NEW Hydrowood Eco Design ca. 8,3 mm**

- Hochstrapazierfähige PU Beschichtung  
Hardwearing PU Protection
- PVC-freie Designauflage  
PVC-free design coverings
- Wasserfeste Holzwerkstoff-Trägerplatte  
Waterproof wood based board
- Presskork Gegenzug  
Cork underlay

- Fusswarm**  
Warm to the touch
- Strapazierfähig**  
Durable
- Schall- und Trittschallisolierung**  
Sound impact and phonic insulation
- Antistatisch**  
Antistatic
- Wärmeisolierend**  
Thermal insulation
- Prägung**  
Embossing



191003-2 Canadian Oak Grey

Formate / Dimensions

1235 x 230 mm

1235 x 305 mm

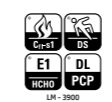



191904 Concrete Donau

## LIPUR

### Der PVC-freie & äußerst resistente Designboden

Lipur ist frei von PVC, Chlor, Weichmachern und Phthalaten. Er erfüllt alle Voraussetzungen für einen wohngesunden Boden.

Der hoch resistente Bodenbelag ist besonders für den Objektbereich ideal (Klasse 34). Durch die Weiterentwicklung in der Oberflächentechnologie wurde eine spezielle Oberflächenstruktur mit authentischer Haptik und eine hochstrapazierfähige PU Beschichtung entwickelt. Lipur ist leicht zu pflegen, sowie äußerst widerstandsfähig gegen Flecken und Kratzern.

### The PVC-free & extremely resistant designfloor

Lipur is free of PVC, chlorine, plasticisers and phthalates. Lipur fulfills all requirements for a healthy living floor.

The highly resistant flooring is ideal for the commercial sector (class 34). Advances in surface technology have resulted in a special surface texture with an authentic haptic and a highly durable PU coating. Lipur is easy to maintain, as well as extremely resistant to stains and scratches.



190701 Eiche Indus / Oak Indus

192609 Eiche Wolga / Oak Wolga



191508 Fichte Rio Grande / Spruce Rio Grande



191808 Eiche Nil / Oak Nil



187702 Eiche Ebro / Oak Ebro



187702 Eiche Ebro / Oak Ebro



170508 Eiche Amazonas / Oak Amazonas



163901 Kiefer Seine / Pine Seine



170513 Eiche Colorado / Oak Colorado



163903 Kiefer Tiber / Pine Tiber



190705 Fichte Kongo / Spruce Kongo



186604 Fichte Don / Spruce Don



187708 Eiche Mekong / Oak Mekong



191503 Fichte Mississippi / Spruce Mississippi



192509 Lärche Ural / Larch Ural



163311 Eiche Po / Oak Po



190701 Eiche Indus / Oak Indus



Kork

Printcork

Lino

Fibrano

Ledo

Realstone

Real DesignWood

Micodur

Vinyl

Hydro Fix

Vintex Fix

Eco Design

Lipur

Zubehör

Lico Wall

164211 Stone Elbe

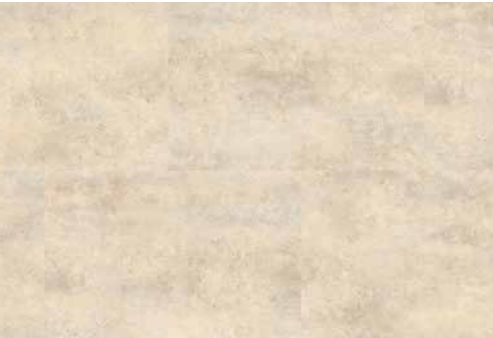

168811 Concrete Maas



191904 Concrete Donau



191912 Concrete Inn



168809 Concrete Oder



168809 Concrete Oder



Klasse / Class 23 / 34  
Klasse / Class 23 / 34

PVC FREE  
100 % PVC frei  
100 % PVC free

Extrem strapazierfähig  
Extremely durable

Fußbodenheizung  
Underfloor heating

Pflegeleicht  
Easy to care

HDF ca. 9,5 mm

- Hochstrapazierfähige PU Beschichtung  
Hardwearing PU Protection
- Lipur
- Feuchtigkeitshemmende Natur Faserplatte  
Moisture retardant fibre-board
- Green Sound - Trittschallunterlage  
Green Sound - sound impact

NEW Hydrowood ca. 9,5 mm

- Hochstrapazierfähige PU Beschichtung  
Hardwearing PU Protection
- Lipur
- Wasserfeste Holzwerkstoff-Trägerplatte  
Waterproof wood based board
- Wasserfester Gegenzug  
Waterproof underlay

Fliese / Tile ca. 1,5 mm

- Hochstrapazierfähige PU Beschichtung  
Hardwearing PU Protection
- Lipur
- Lipur

- Fusswarm**  
Warm to the touch
- Dimensionsstabil**  
Dimensionally stable
- Schall- und Trittschallisolierung**  
Sound impact and phonic insulation
- Verwendung nachwachsender Rohstoffe**  
Use of regrowing raw material
- Wärmeisolierend**  
Thermal insulation
- Gelenkschonend**  
Soft to the tread

192509 Lärche Ural / Larch Ural



Formate / Dimensions

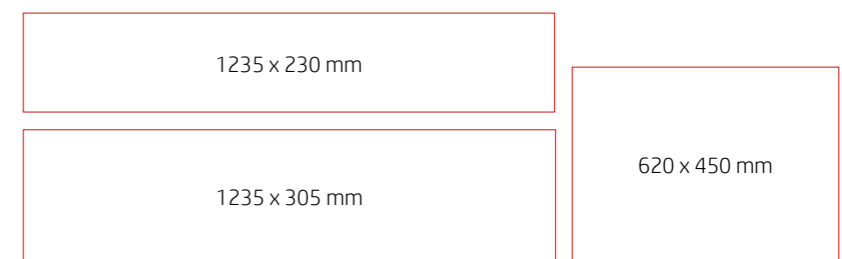

Kork  
Printcork  
Lino  
Fibrano  
Ledo  
Realstone  
RealDesignWood  
RealDesignWood  
MicoDur  
Vinyl  
Hydro Fix  
Vintex Fix  
Eco Design  
Lipur  
Zubehör  
Lico Wall



Treppenkante Klassik mit Seitenabschluss / stair classic with side-finishing  
Vinyl Design 16 1122-2 Walnuss / 1122-2 Walnut

## LICO ZUBEHÖR LICO ACCESSOIRES

Kork

Printcork

Lino

Fibrano

Ledo

Realstone

Real DesignWood

Micodur

Vinyl

Hydro Fix

Vintex Fix

Eco Design

Lipur

Zubehör

Lico Wall

Lico Wall

Lico Wall

Lico Wall

Lico Wall

Lico Wall

Lico Wall

Lico Wall

Lico Wall

Lico Wall

# STAIRS

## Die Treppenstufen passend zu Ihrem Boden

LICO Treppenstufen-Systeme erlauben es, Treppen im selben Design und Aufbau, sowie in gleicher Struktur und Farbe, gleich dem Bodenbelag, zu gestalten. Die Treppenstufen sind mit der bewährten Klickverbindung ausgestattet und verfügen somit über eine nahtlose Verbindung in allen Verlege-Richtungen (ohne „Nase“). Zusätzlich wird eine Variante mit „Nase“ angeboten, sollte nur der Tritt gewünscht sein. Ein Seitenabschluss (links oder rechts) kann optional gewählt werden.

### The stairs to match your floor

LICO stairs provide the possibility to get stairs with the same design, structure, colour and material as the floor. The stairs provide the established self-locking system, therefore they show a seamless connection in all directions (without “nose”). Additionally, there is also available a version with “nose”, if only the footstep is required. A side finishing can be also chosen (left or right).

Erhältlich in / Available in:

LICO Vinyl

XXL Trittläche / XXL tread

Stufentiefe von > 40 cm / Step depth of > 40 cm

\* Massangaben in mm / Measurements in mm

### Treppenkante Klassik Stair Classic

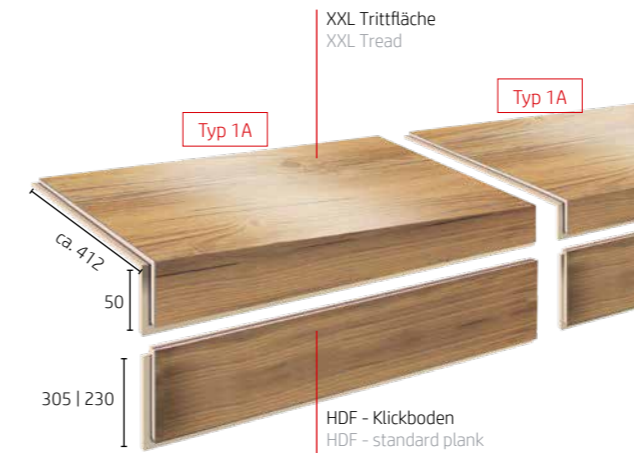

Die Länge der Treppenkante - Dielenformat  
The length of the stair - size of the boards  
1800 mm, 1220 mm, 900 mm

### Treppenkante Klassik mit Seitenabschluss Stair Classic with side finishing

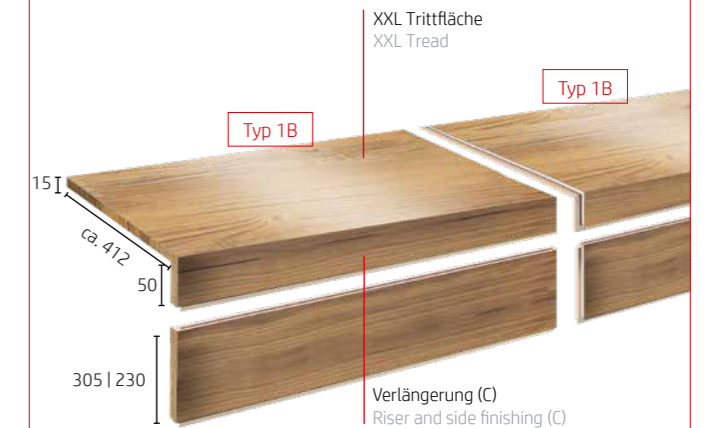

Die Länge der Treppenkante - Dielenformat  
The length of the stair - size of the boards  
ca. 1800 mm, 1220 mm, 900 mm

Seitenabschluss rechts oder links möglich  
Side finishing is left or right possible

### Treppenkante mit Nase Stair with nose

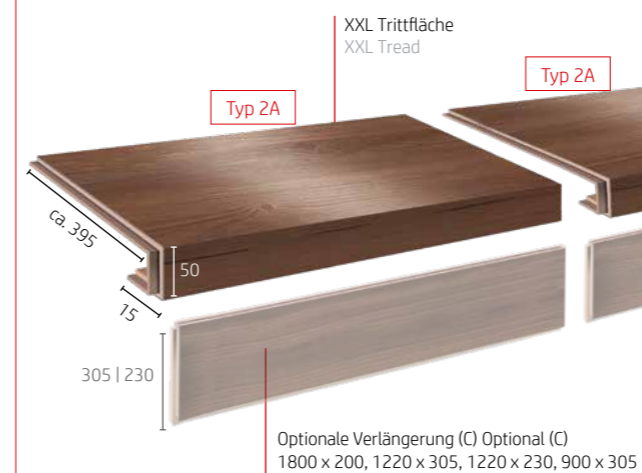

Die Länge der Treppenkante - Dielenformat  
The length of the stair - size of the boards  
1800 mm, 1220 mm, 900 mm

### Treppenkante mit Nase und mit Seitenabschluss Stair with nose and with side finishing



Die Länge der Treppenkante - Dielenformat  
The length of the stair - size of the boards  
1800 mm, 1220 mm, 900 mm

Seitenabschluss rechts oder links möglich  
Side finishing is left or right possible



## SKIRTINGS

### Die Sockelleisten passend zu Ihrem Boden

LICO Sockelleisten ermöglichen es, die Sockelleisten genau dem Bodenbelag anzupassen, das heisst, dass es zu jedem LICO-Boden auch die identisch dazugehörigen Leisten gibt, welche sich weder in Design, Struktur und Farbe, noch materialtechnisch vom Bodenbelag unterscheiden. Die leicht zu handhabenden Sockelleisten sind mit derselben bewährten Klickverbindung wie der Bodenbelag versehen, welche einen versatzlosen Übergang gewährleistet. Das Produkt kann geschraubt, geklebt oder auch genagelt werden. Zudem ist die Form so gewählt, dass ein dezenter und harmonischer Abschluss des Bodenbelages gegeben ist.

### The skirtings to match your floor

LICO Skirtings can be adjusted exactly to the floor, in other words, for every LICO FLOOR there are the identical appropriate skirting boards which are equivalent to the floor in design, structure, colour and material. The skirtings are easy to handle and provide the established self-locking system, which guarantees a seamless connection.

They can be assembled by screwing, gluing and nailing. Its given a discreet and harmonic conclusion of the floor.

### Sockelleisten Konisch Skirtings Conical

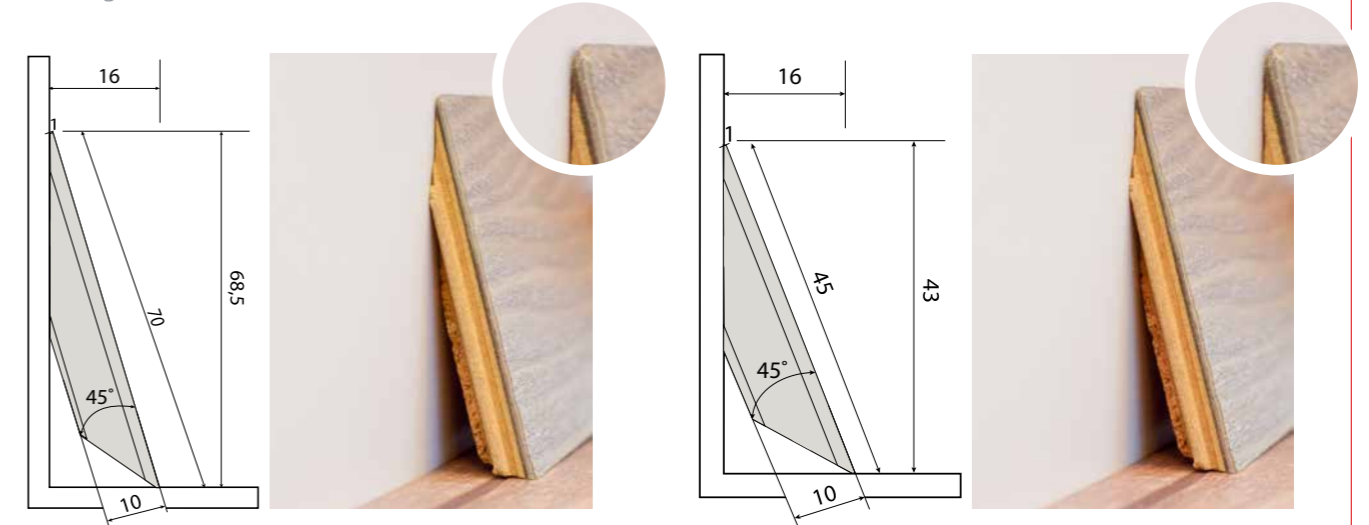

Erhältlich in / Available in: **allen Produktlinien / all product lines**

### Sockelleisten Klassik Skirtings Classic

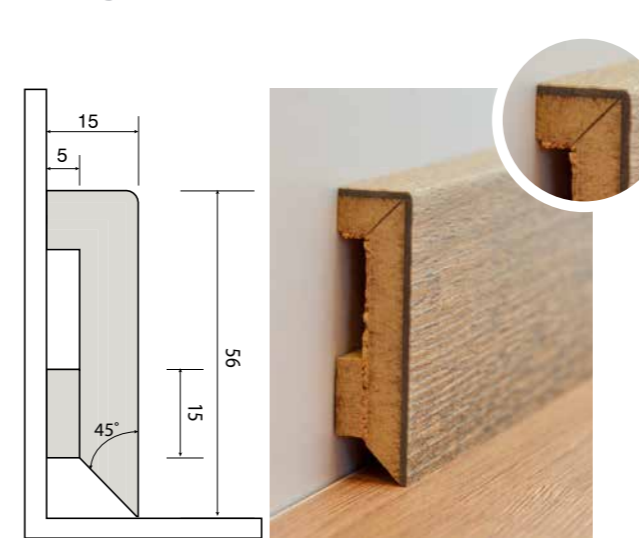

Erhältlich in / Available in: **LICO Vinyl**

### Sockelleisten Konisch Swing Skirtings Conical Swing

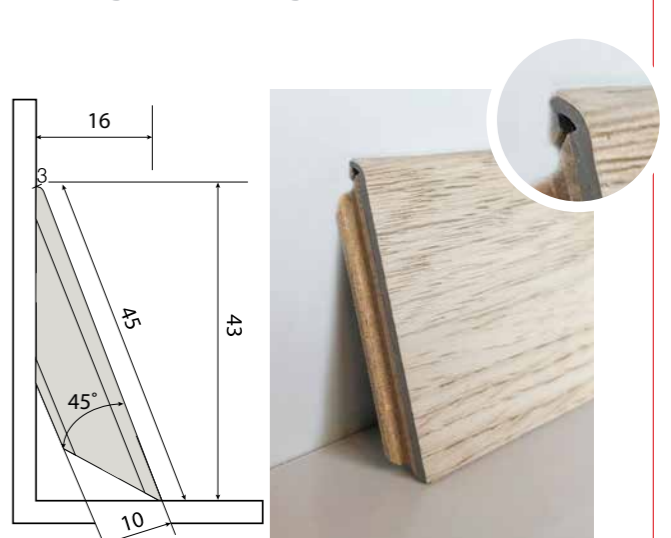

Erhältlich in / Available in: **LICO Vinyl**





## LICO WALL

Die Wandverkleidung  
Wall covering

W212 Steinwand Ornament / Stone Wall Ornament

Kork

Printcork

Lino

Fibrano

Ledo

Realstone

Real DesignWood

Micodur

Vinyl

Hydro Fix

Vintex Fix

Eco Design

Lipur

Zubehör

Lico Wall

111

110





949 Marmor Calacatta

-   
 Kein Telegraphen Effekt  
No telegraph effect
-   
 Lichtechtheit >6  
Lightfastness >6
-   
 Wasserdicht  
Waterproof
-   
 Nut-Feder Verbindung  
Tonge and groove connection
-   
 Raumhohe Paneele  
Room-high panels

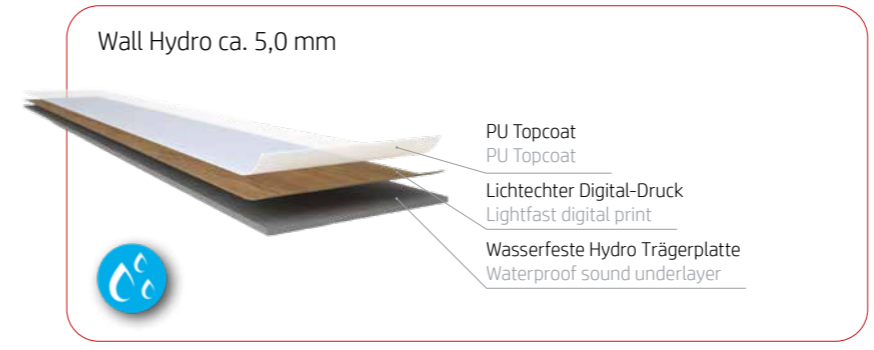

Formate / Dimensions



1280 x 460 mm

935 x 2600 mm  
**XXL**

- Kork
- Printcork
- Lino
- Fibrano
- Ledo
- Realstone
- Real DesignWood
- Micodur
- Vinyl
- Hydro Fix
- Vintex Fix
- Eco Design
- Lipur
- Zubehör
- Lico Wall



Hydro Wall Print Dekore ab jetzt auch mit 3D Druck erhältlich  
Hydro Wall Print decors now also available with 3D printing

W229 Concrete Polished White



W226 Arcadia Light



W252 Letter Beige



W232 Moonstone Light



W231 Moonstone Bronze



W233 Moonstone Silver



W212 Steinwand Ornament / Stone Wall Ornament



W234 Cement Gres



W246 Eiche Akzent / Oak Accent



W224 Arcadia



W221 Florence Copper



W217 Copper Leaves



## WALL HYDRO PRINT

### Die individuelle Wandverkleidung

Wall Hydro Print lässt Sie Ihre persönlichen Designwünsche realisieren, denn mittels lichtechtem (>7) Digitaldruck ist es möglich, die wasserfesten Paneele mit jedem beliebigen Design zu bedrucken – egal ob Panoramabild, Steinmauer oder Fantasygrafik. Diese Wandverkleidung ist die optimale Lösung, wenn sie sich hinsichtlich Stil, Farbe und Design perfekt in den Raum einpassen soll und eröffnet somit völlig neue Möglichkeiten in der modernen Wandgestaltung.

### The individual wall covering

Wall Hydro Print allows you to realize your personal design wishes, as it is possible to print the waterproof panels with any design by lightfast (7/8) digital printing – no matter if panoramic picture, stone wall or fantasy graphic. This wall covering is the optimal solution if it is supposed to perfectly fit into the interior in terms of style, color and design and opens up completely new possibilities in modern wall design.

W224 Arcadia mit 3D Druck / with 3D print

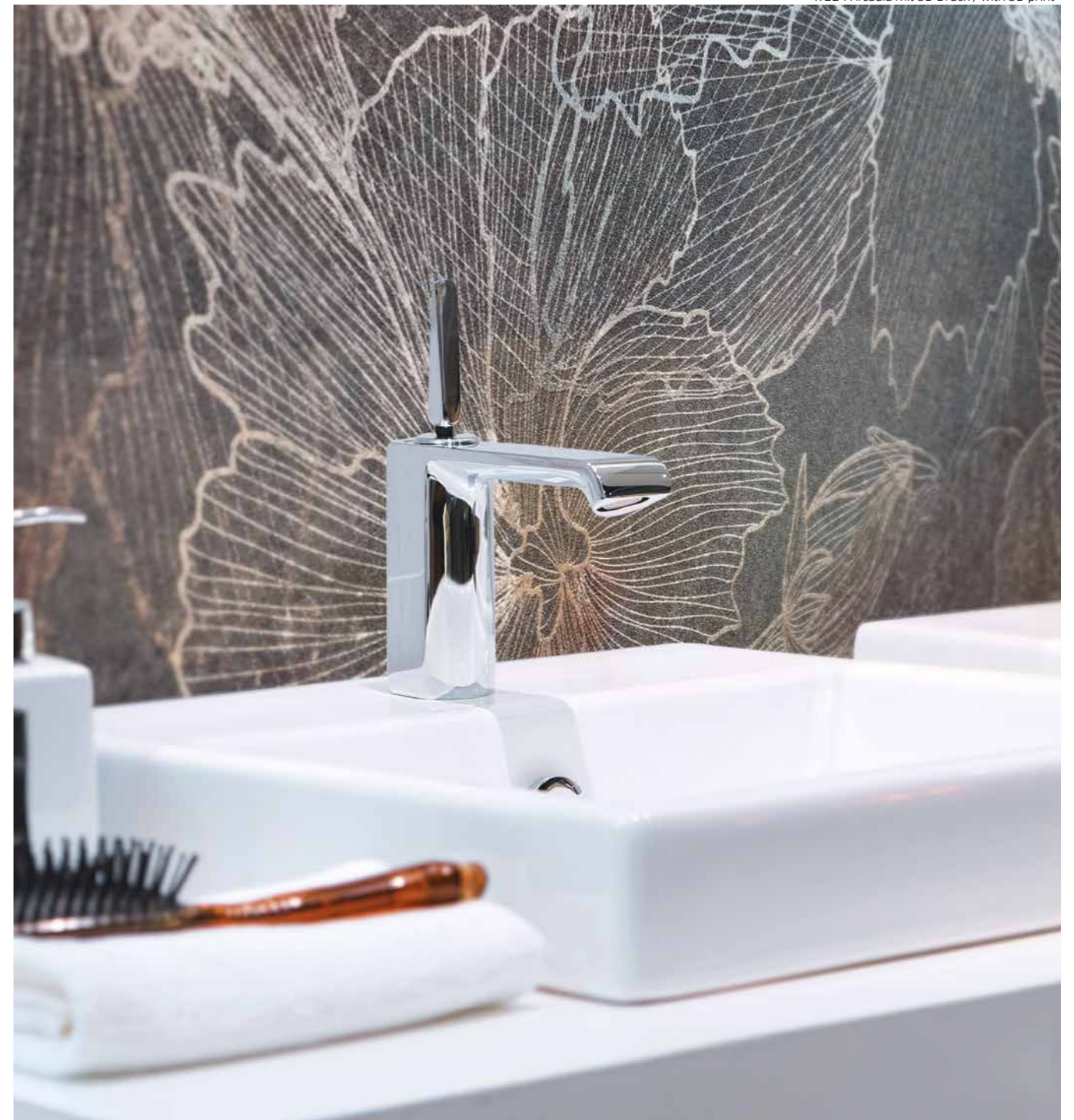



W217 Copper Leaves mit 3D Druck / with 3D print

- Wasserdicht  
Waterproof
- Lichtechtheit >7  
Lightfastness >7
- Kein Telegraphen Effekt  
No telegraph effect
- Nut-Feder Verbindung  
Tongue and groove connection
- Raumhohe Paneele  
Room-high panels

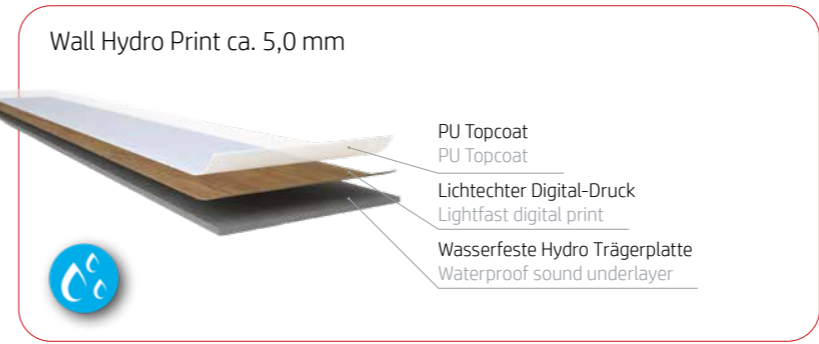

W231 Moonstone Bronze



Formate / Dimensions

1280 x 460 mm

935 x 2600 mm

**XXL**

- Kork
- Printcork
- Lino
- Fibrano
- Ledo
- Realstone
- Real DesignWood
- Micodur
- Vinyl
- Hydro Fix
- Vintex Fix
- Eco Design
- Lipur
- Zubehör
- Lico Wall**



**Li&Co AG**  
 Palü Daint 226  
 CH-7537 Müstair

TEL +41 (0)81 850 38 38  
 FAX +41 (0)81 850 38 39  
 info@lico.ch  
 www.lico.ch



